

INSTRUCTION MANUAL

PRIMALRC

TRACTION
HOBBY

PORSCHE



1/6
SCALE

4WD

2.4G
Radio

150A
Brushless ESC

LED
Lights

RWD

4274
Brushless Motor

3-6S
Li-Po

Thank you for purchasing this Primal RC and Traction Hobby product! This manual contains the instructions you need to operate and maintain your vehicle. It is very important that you take the time to read and understand the instructions and radio manual. Make sure you read and follow the precautions and warnings in the Safety Guidelines section. These guidelines will educate you on how to run your vehicle safely and maximize its longevity and performance.

This vehicle requires advanced R/C user experience and expertise. Even if you are an experienced R/C driver, it is important to read and follow the safety guidelines in this manual.

If you have any questions regarding this vehicle or this manual: Stop. Do not use this vehicle and contact us at sales@primalrc.com.

Thank you again for your purchase and we look forward to exceeding your expectations.

Safety Guidelines:

WARNING – RISK OF FIRE, INJURY OR DEATH

This vehicle is not a toy. The vehicle requires an advanced set of skills and is not intended for use by children or minors under the age of 18. The vehicle is intended to be purchased and operated by competent, adult R/C users possessing qualified skills and experienced driving ability. The user of this vehicle should be practical, mature, intelligent and display good common sense.

Caution must be taken to ensure the safety of yourself and others around you. This vehicle is large and is capable of high speed and quick acceleration. Collisions of a critical nature (injury, death, severe property damage) can result if the vehicle is operated in a careless or unsafe manner. Always take great care to make sure all systems are working properly before operating. The user must be aware of their limits and abilities. Make certain to have adequate space where the vehicle can be run safely.

Please read and understand the proper procedures for charging your Li-po battery. The user must read and understand all the included instructions regarding proper operation, maintenance and safety precautions in using and charging Li-po batteries.

Terms of Use:

This product is sold by Primal RC and Traction Hobby with the understanding that the buyer accepts full responsibility for all actions associated with its use. Serious injury, property damage, or death can result from driving the vehicle or using any of the included accessories in an unsafe or irresponsible way. The buyer assumes all liability with this product, including any actions that occur due to a failure to follow its safety and operating instructions resulting in unsafe or improper use or any action that violates the pertinent laws and regulations. Primal RC, and all the Primal RC dealers, will not be held accountable under any circumstances with the use of this product resulting in property damage, personal injury, or death. This includes any willful or unintentional damage that may arise from the assembly or use of the product or its accessories. The user accepts all liability by the act of using and operating the vehicle and releases Primal RC, and all Primal RC dealers of all liability associated with its use. Primal RC requests that you do not use this product if you as a user do not accept liability of ownership.

If you don't accept liability, please do not open any of the enclosed accessories, do not attempt to start it, and contact us to make arrangements to return the product. Used vehicles cannot be accepted for returns or exchanges under any circumstances. The material included in this manual can be changed without notice. Primal RC reserves the right to make improvements to the products with no commitment to integrate those improvements into products sold previously. The manual is subject to change at the discretion of Primal RC. For the latest version of the manual please visit www.PrimalRC.com. If you have any questions regarding these Terms of Use, stop and do not go any further. Do not run your vehicle and contact Primal RC at sales@primalrc.com.

Safety is your responsibility:

- Your radio system may be subject to radio interference from many sources that are out of your control. Please be aware that radio interference may cause a temporary loss of control. Allow adequate space in all directions when running your vehicle to prevent collisions if radio interference should occur.
- Test the range of your transmitter in the area you are driving. Make sure not to drive too far and go out of range.
- After testing the range, start by driving slowly in the area to make sure there is no interference that can cause temporary losses of control.
- Drive in the proper area. This product is not designed to be used in heavy traffic areas where its operation would cause pedestrian and vehicle interruptions. This is recommended to prevent collisions causing property damage, injury, or death.
- Try to always bring a friend while driving. Another set of eyes is helpful to identify potential hazards such as an animal or person crossing in the driving path.
- Always have a clear view of the model when driving. Do not drive at night or when your vision may be blocked in any way.
- Don't drive the model too close to you, other people, or property where collisions may occur. Allow a comfortable amount of space to maneuver the vehicle.
- Be sure to check over the vehicle after each driving session. Check for damage or any loose parts and correct any issues right away before driving again. Make sure to check and tighten the wheel nuts before each session.
- Do not pick up the vehicle from its wheels or tires. Keep your hands free and clear of any moving parts when the electronics are turned on. Gravel, dirt, sticks, and other debris can be kicked up from the rear wheels during aggressive starts. Avoid standing directly behind the vehicle and make sure other viewers are at a safe distance to avoid being hit. Eye protection is always recommended.
- Avoid making changes not shown or suggested in the instruction manual. You can cause damage to the model and injury to yourself or others if the product is altered in a way not intended.
- Remember: **SAFETY FIRST**. Create a safe environment to run the vehicle and use good common sense. This will ensure maximal enjoyment while using the vehicle.

Before you Drive:

- Install AA Batteries in transmitter.
 - Open battery cover at the bottom of transmitter. Install batteries. Follow the + and – markings inside battery compartment.
 - Always check transmitter batteries are charged before starting to drive.
- Charge the Li-po Battery for the vehicle.
 - The stock electronics support only 4S or 6S Li-po Batteries.
 - Only use a battery with the same connector as the stock electronics.
 - Charge the battery in a safe environment.
 - Do not use Ni-Cd/Ni-MH battery chargers for Li-po batteries. Failure to use a Li-po charger with your Li-po battery can result in property damage, injury, or death.
- Install Li-po Battery into Vehicle.
 - Check battery compartment fits battery with a snug fit.
 - Adjust tray size and straps as needed.
 - Check battery straps are tight.
- Check over the vehicle to make sure there are no loose screws.
 - Check wheel nuts are tight.

How to properly turn On your vehicle to begin driving:

- Place the vehicle on a stand so the wheels can freely spin.
- Remove vehicle's body.
- Turn On the transmitter FIRST.
- Check vehicle ESC switch is OFF.
- Plug in Li-po Battery to ESC.
- Do not touch transmitter controls, turn On vehicles ESC switch.
- ESC will make an initialization tone and flash, then it will beep the number of Li-po battery pack cells you are using, followed by an arming tone. After the arming tone plays, the ESC will ACTIVE and will respond to the throttle application.
- With the vehicle still on a stand and the wheels unobstructed, gently apply throttle, brake, and steering. Check all controls function as expected.
- Refer to transmitter manual for specifics on changing radio settings as needed.
- Securely attach vehicle body, remember to plug in LED lights connector.
- Enjoy!

While Driving:

- Do not run on public streets or highways. This could cause serious accidents, personal injuries, and/or property damage.
- Do not run in water or sand.
- Allow the vehicle to cool down for 15 minutes between each run.
- Make sure to check motor and battery temperature while running. Exceeding maximum operating temperature of motor or batteries may result in damage.
 - Motor Max Temperature: 190F, 88C
 - Battery Max Temperature: 140F, 60C
- Safety Function of The Speed Controller:
 - If the ESC temperature exceeds 200F (90C), ESC will automatically shut down and RED LED will blink.
 - Once the ESC has cooled down to normal temperature, it will work as normal.
- This vehicle is also equipped with a 2WD to 4WD shifting system. Always bring the vehicle to a stop before shifting the drivetrain, this will prevent damage to the transmission shifting system.

After you Drive:

- Bring the vehicle to a stop in a safe place.
- Remove vehicle's body.
- Turn Off vehicle ESC switch FIRST. Do not turn the transmitter Off yet!
- Unplug Li-po battery and remove it from the vehicle.
- Turn Off the transmitter.
- Always disconnect the battery when you are not running the vehicle. The vehicle may run out of control, or the battery can over discharge and cause a fire.
- Always store Li-po batteries outside of the vehicle.
 - Keep batteries in a safe place away from flammable objects, use a Lipo safe storage bag if possible.
- Check over the vehicle to make sure there are no loose screws.
 - Check wheel nuts are tight.
- Perform regular maintenance to keep your vehicle performing at its best. See Maintenance section.

Maintenance Guide:

Battery Packs Run	Maintenance
Every 1-2 Packs	<ul style="list-style-type: none">o Inspect and tighten all screws and wheel nutso Check for damage (chassis, suspension, body)o Clean off dirt and debris (soft brush or compressed air)o Wipe down shocks and drive shaftso Inspect tires for cuts or damageo Check throttle and steering control for smooth functiono Lightly lubricate moving joints with WD-40 or light oil
Every 5 Packs	<ul style="list-style-type: none">o Remove wheels, inspect wheel hex hubs and pinso Check shocks for leaks or physical damageo Inspect suspension arms and hinge pins for wearo Clean and inspect drivetrain for dirt or bindingo Re-grease exposed drive cups and universalso Clean ESC/motor cooling fans (if applicable)
Every 10 Packs	<ul style="list-style-type: none">o Inspect and clean all gears (spur, pinion, diff input, center gear)o Re-lubricate drivetrain gearso Check motor mount screws and pinion gear mesho Check servo horn tightness and servo savero Inspect ball joints and steering linkages for excessive plo Test 2WD/4WD shift function; inspect servo endpointo Inspect LiPo connectors for wear, corrosion, or loosenesso Replace shock oil (or sooner if oil looks dirty or handling worsens)
Every 15-20Packs	<ul style="list-style-type: none">o Replace shock oil (or sooner if oil looks dirty or handling worsens)o Replace differential oilo Inspect and clean bearings throughout chassiso Monitor ESC and motor for thermal wearo Inspect chassis and mounts for cracks or fatigue
As Needed	<ul style="list-style-type: none">o Replace tires, foam inserts, or stripped screwso Replace spur/pinion gear if chippedo Replace weak or jittery servoso Replace puffed or unbalanced Li-Po

Troubleshooting Guide:

● Motor or ESC Overheats

- o Add a cooling fan and heatsink to the motor.
- o Motor may be over-gearred – install lower gearing.
- o Transmission may be seized – inspect drivetrain for binding or debris.

● Motor Runs, But Wheels Do Not Move

- o Pinion gear may be loose or not meshed correctly.
- o Drive pin broken or missing – check wheel hex.
- o Transmission may be jammed – inspect gears and drivetrain.

- **Vehicle Turns On, But Motor Does Not Move**
 - Ensure transmitter is on
 - Check that the vehicle's battery is fully charged and properly connected.
 - Refer to ESC manual for error codes or LED status.
 - Inspect motor wires and connectors for damage.
 - Remove and test motor separately to confirm it's functional.

- **Throttle Direction Is Reversed**
 - Use the transmitter's reverse function
 - Recalibrate ESC throttle range (refer to ESC manual)
 - Unplug and swap 2 of the 3 motor wires, recalibrate ESC, test drive again.

- **Vehicle Does Not Drive Straight**
 - Adjust steering trim on the transmitter.
 - Inspect front suspension and steering links for binding or damage.

- **Steering Is Reversed**
 - Use steering reverse function in the transmitter settings.

- **Servo(s) Not Responding or Transmitter Not Connecting**
 - Ensure transmitter is ON.
 - Confirm vehicle battery is plugged in and switched ON.
 - Check all wire connections are secure.
 - Ensure all batteries are charged.
 - Confirm transmitter and receiver are bound – see radio manual.
 - Try moving servo by hand – gears may be stripped.

- **Steering Servo Is Jittery, Buzzing, or Won't Center**
 - Servo may be reaching travel limits – adjust EPA (end points).
 - Check for binding in steering linkage or servo saver.
 - Tighten loose servo horn screw.
 - Inspect servo gears for damage or wear.

- **Drivetrain Making Unusual Noises**
 - Check for loose pinion/spur gear or incorrect gear mesh.
 - Inspect gears and diffs for broken or worn teeth.
 - Look for debris (rocks, sand, twigs) in gears or drive shafts.
 - Ensure center driveshaft set screws are tight.
 - Vehicle Does Not Shift Into 2WD or 4WD.

- **Increase shift servo endpoints in the transmitter (refer to manual)**
 - Only shift when the vehicle is completely stopped
 - If stuck, gently roll the vehicle or tap throttle to help complete the shift

- **Radio Interference or Loss of Control**
 - Test range before use
 - Check for nearby interference sources (Wi-Fi, metal structures, power lines)
 - Ensure receiver antenna is intact and properly positioned
 - Try re-binding transmitter and receiver
 - Use fresh or fully charged transmitter batteries

- **Vehicle LED Lights Not Turning On**
 - Press the LED light mode button on the transmitter
 - Check that LED connectors are securely plugged in
 - Inspect LED harness for pinched or damaged wires

Components

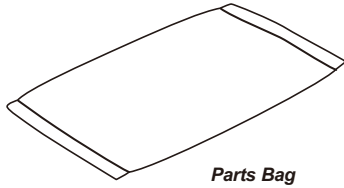

Parts Bag

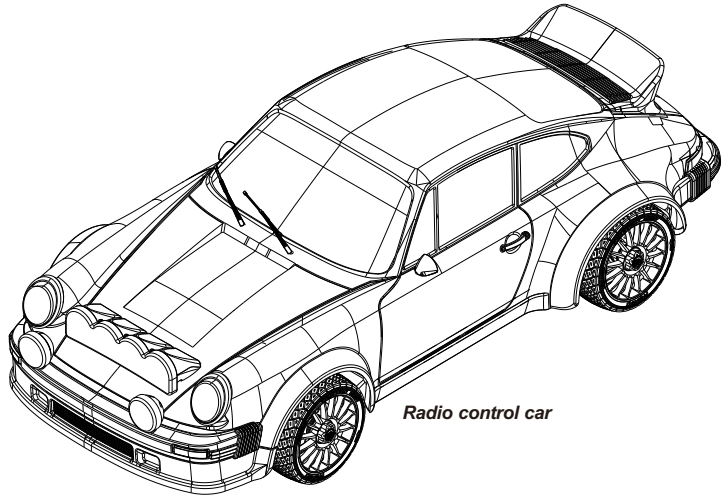

Radio control car

Included Items

wrench

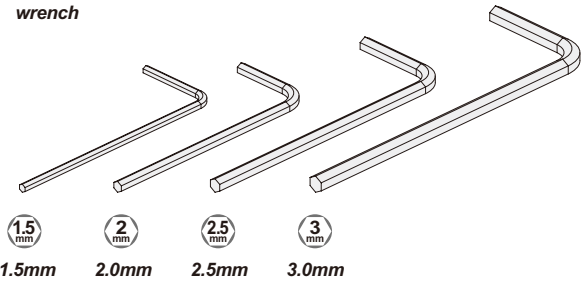

1.5mm 2.0mm 2.5mm 3.0mm

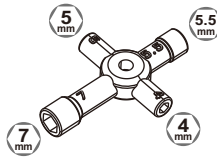

Cross Wrench

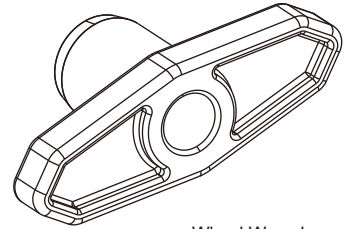

Wheel Wrench

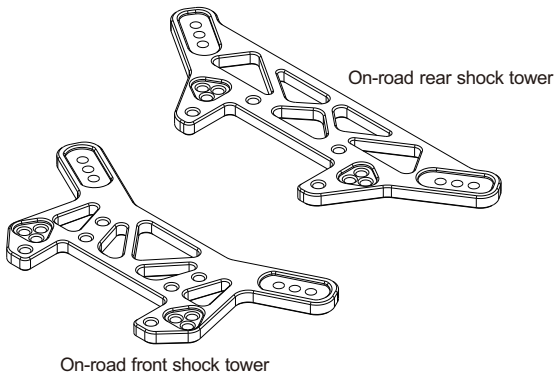

On-road front shock tower

On-road rear shock tower

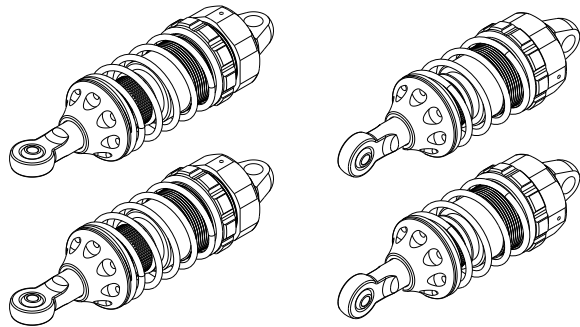

On-road front shocks(long)

On-road rear shocks(short)

Equipment Needed

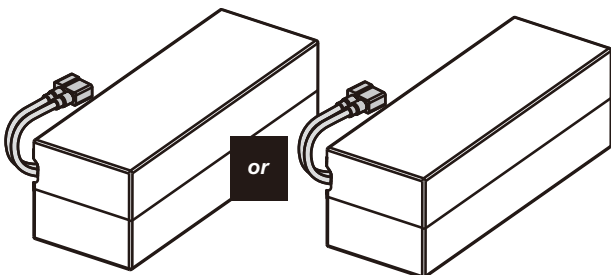

4s(14.8v) LIPO BATTERY PACK

6s(22.2v) LIPO BATTERY PACK

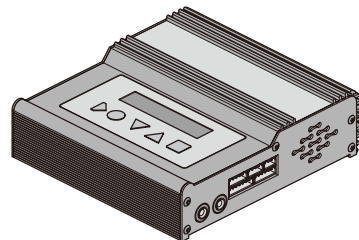

LI-PO CHARGER

Do not use NiCd/NiMH battery chargers for LiPO batteries. If you do not use a special charger for LiPO batteries, they will be damaged.

Maximum battery dimensions
158mm×50mm×60mm

Chassis top view

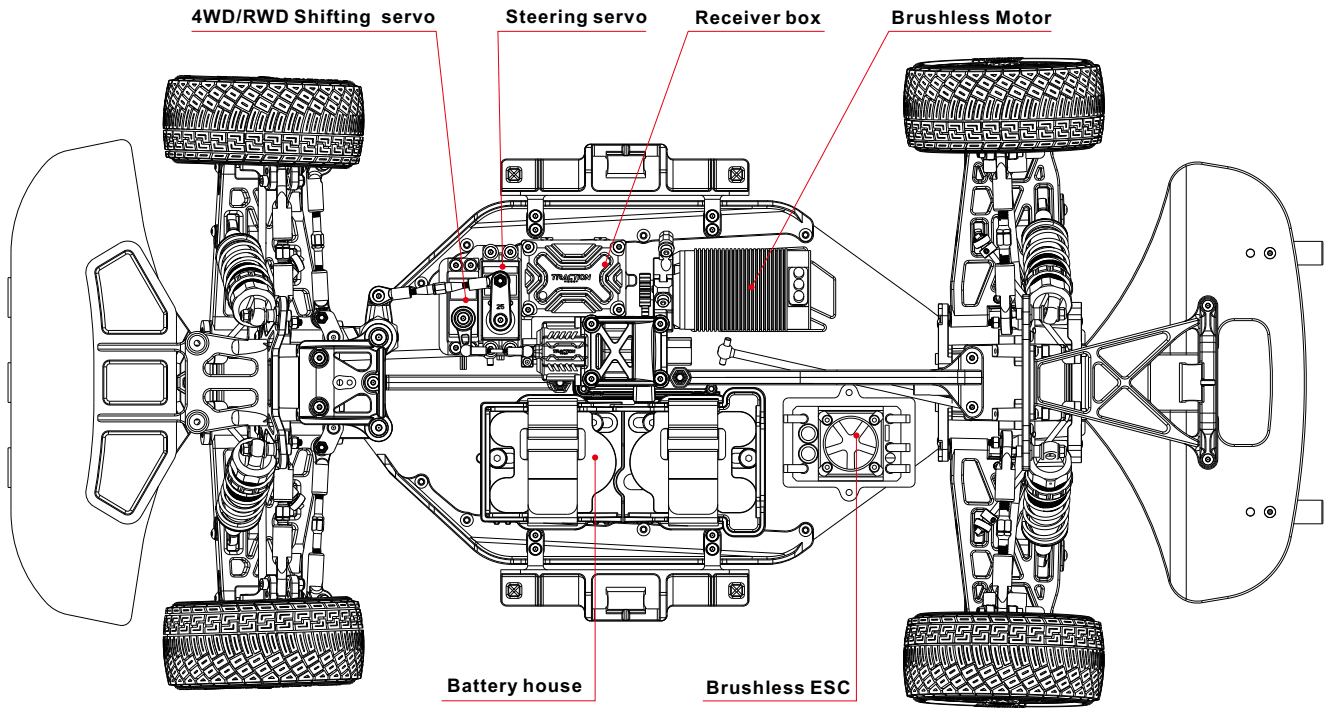

Receiver Connection

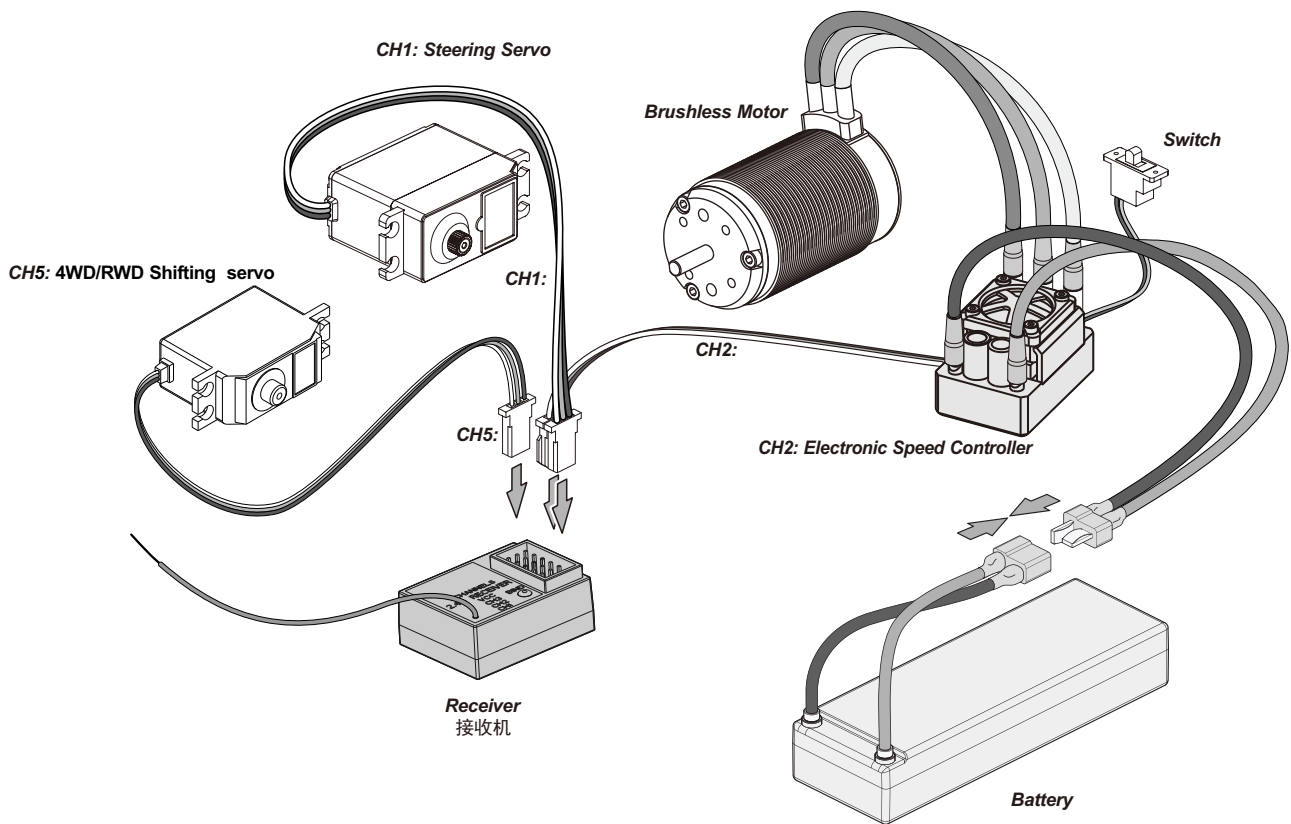

Attention: The lighting system shall be connected to CH1 and CH2 channels , and light control signal line connected to CH3 channel according to the instructions of the lighting system manual.

Transmitter

CH5: 2WD / 4WD Switch

CH1: Steering

On / Off

CH2: Throttle

CH3: LED Light Mode

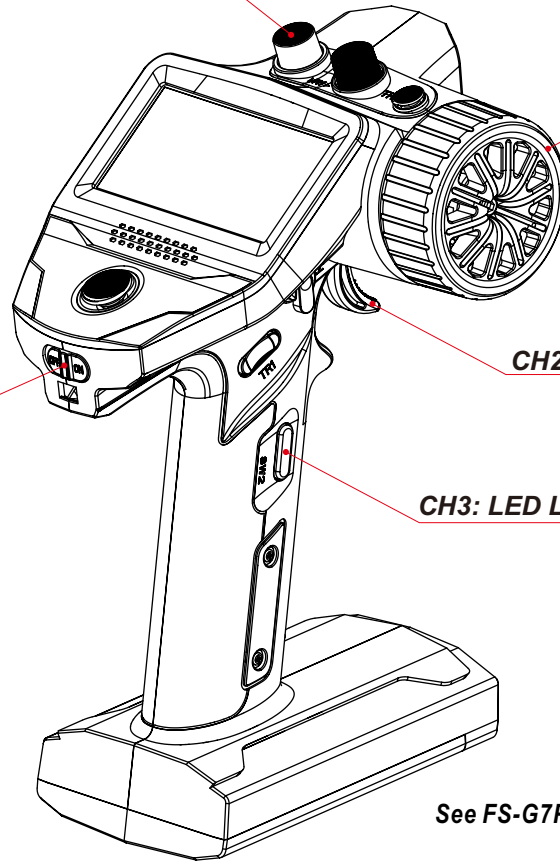

See FS-G7P User Manual for more information

Removing the Body

Pinch Rear and Side Clips,
Pull Body Forward and Up

Note: LED Wire Connector

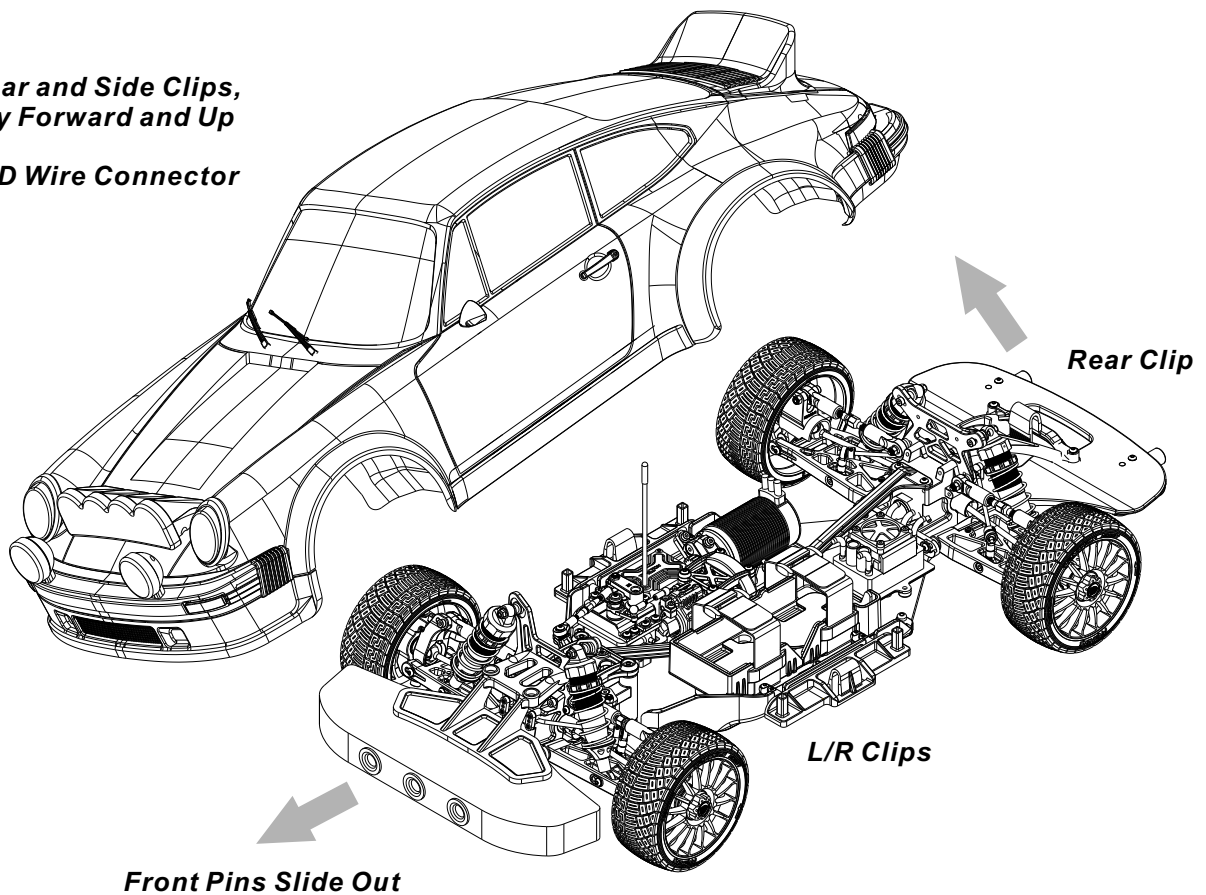

Video Tutorials

Scan the QR code below to watch video tutorials with more detailed instructions on how to set up and use your new RC car.



<https://primalrc.com/porsche-934-video>

01 **×2**

THP2514
PIN 2.5×14mm

×4

TW041003
Washer 4×10×0.3mm

×8

TW061601
Washer 6×16×0.1mm

×6

TW061605
Washer 6×16×0.5mm

×4



TRD10020
O-ring D10×2mm

×4

TBB081605
Bearing 8×16×5mm

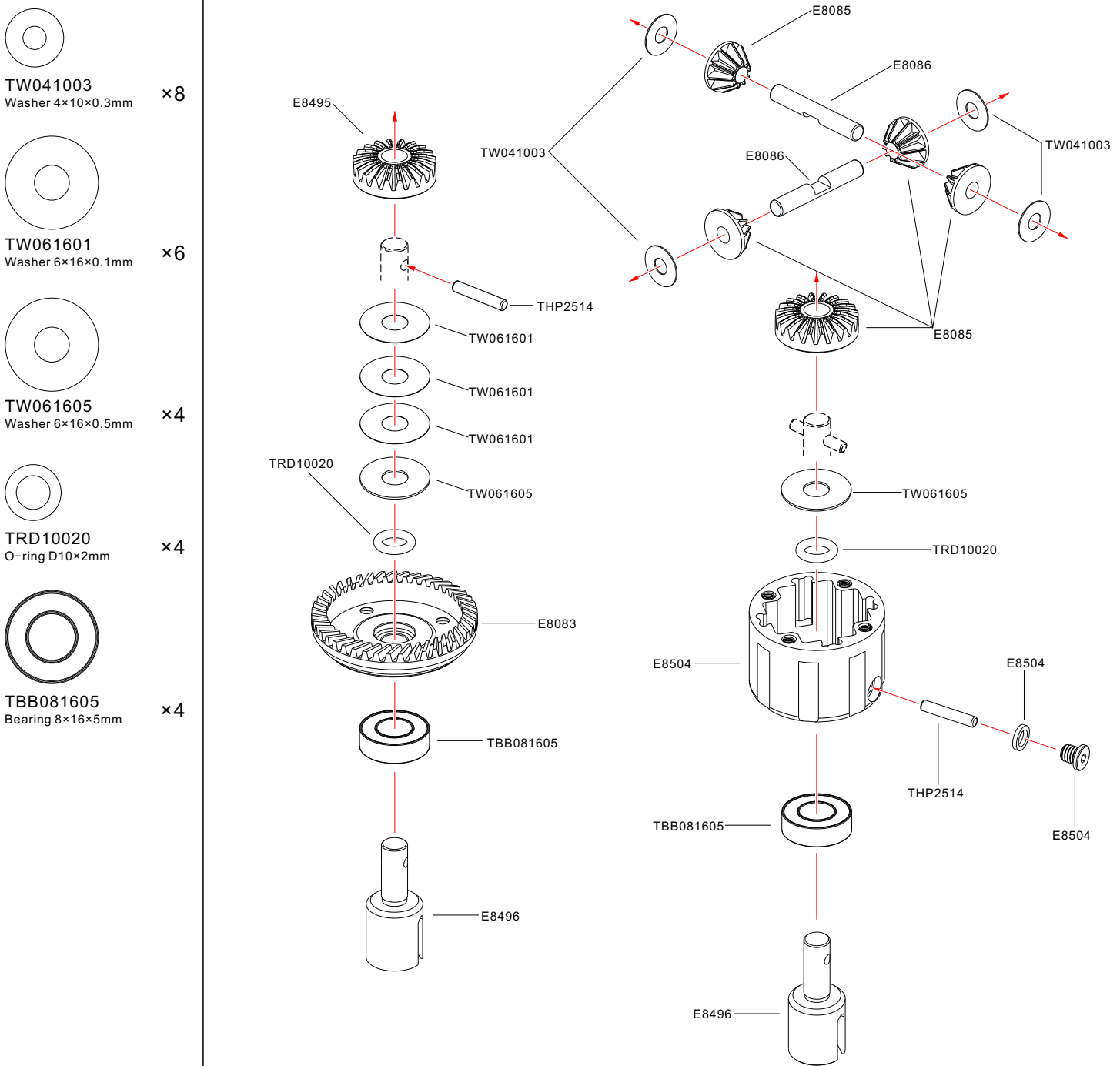
×4

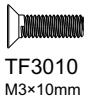



TF3010
M3×10mm

×8

02

F/R

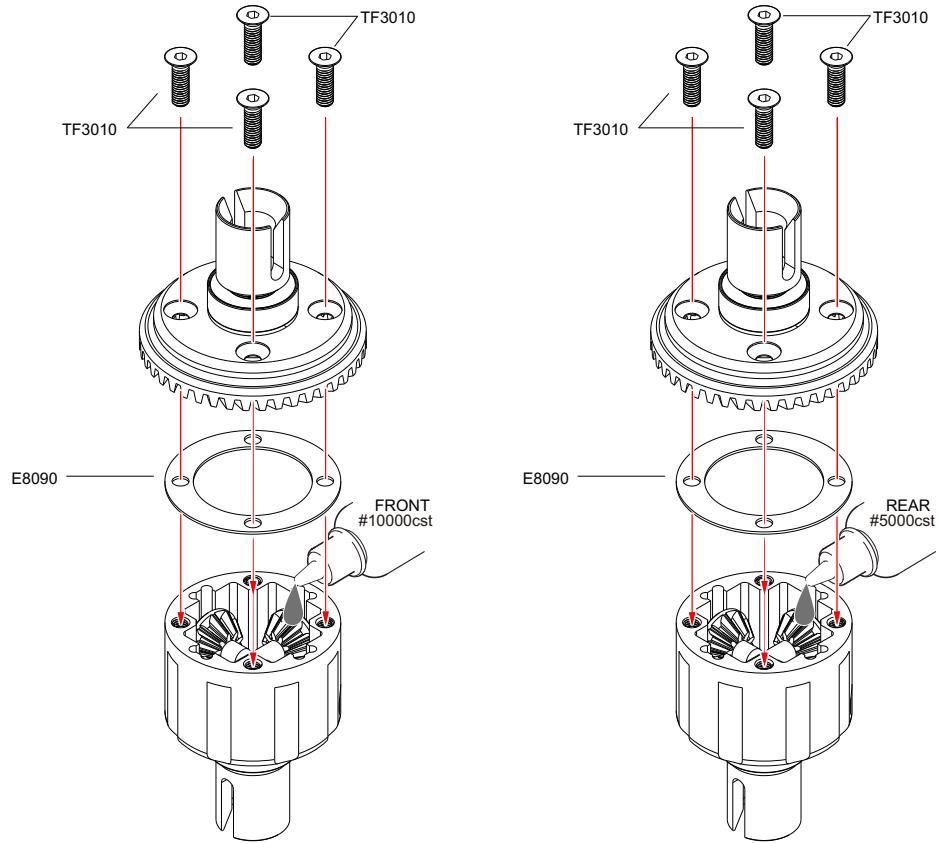

03

×4



TMN25
M2.5 Nylon Nut

×4



TW030705
Washer 3×7×0.5mm

×4

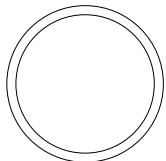

TRD21010
O-ring D21×1mm

×4

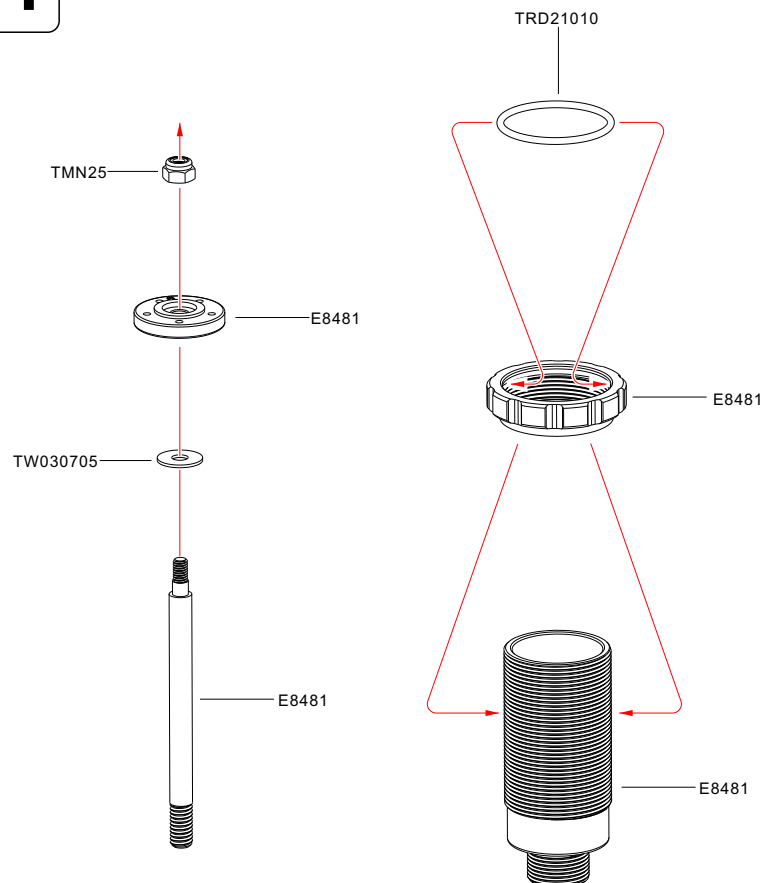

04 **×4**



TRD07519
O-ring D7.5×1.9mm

×8



TRD12012
O-ring D12×1.2mm

×4

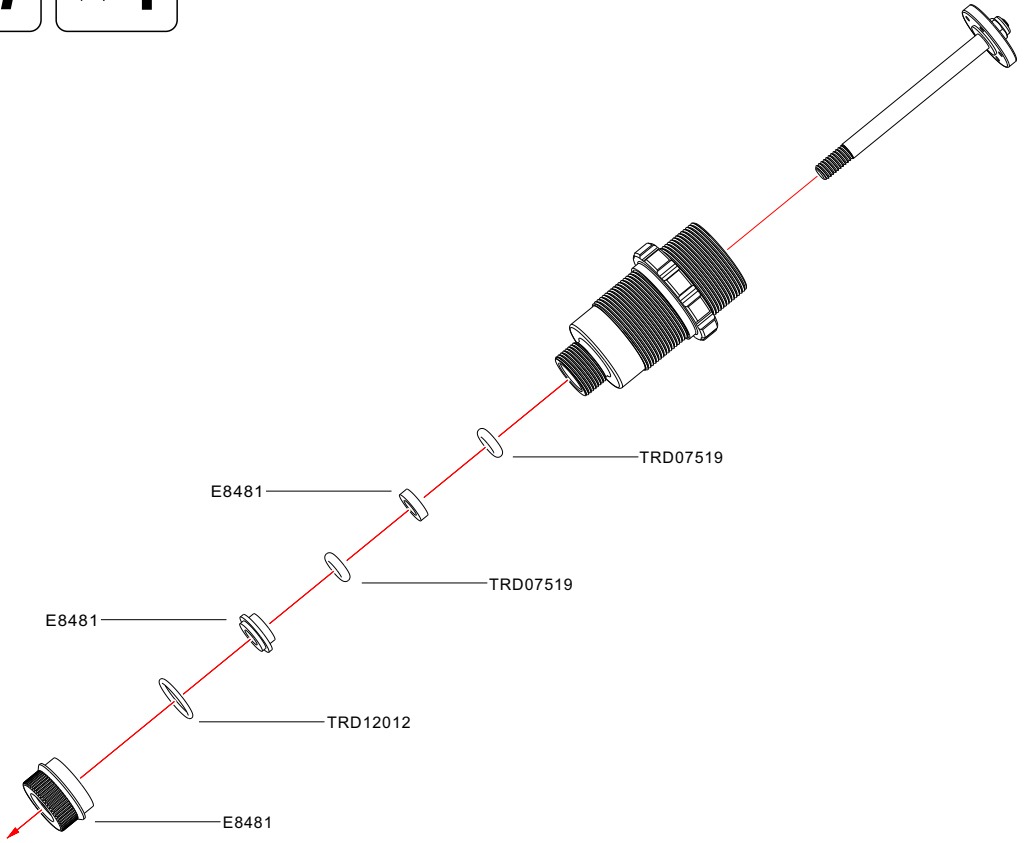

05 **×4**

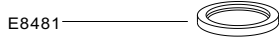
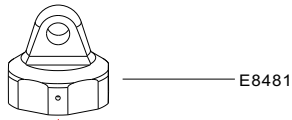

Shock Oil
#400cst

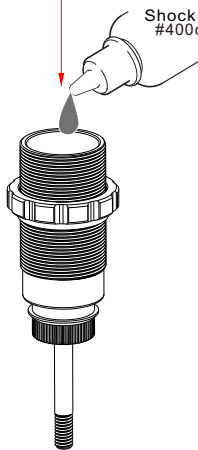

Front shock

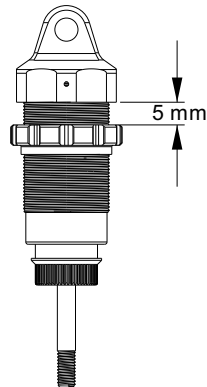

Rear shock

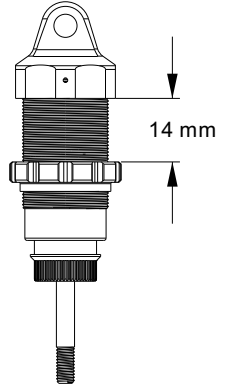

06 **×4**

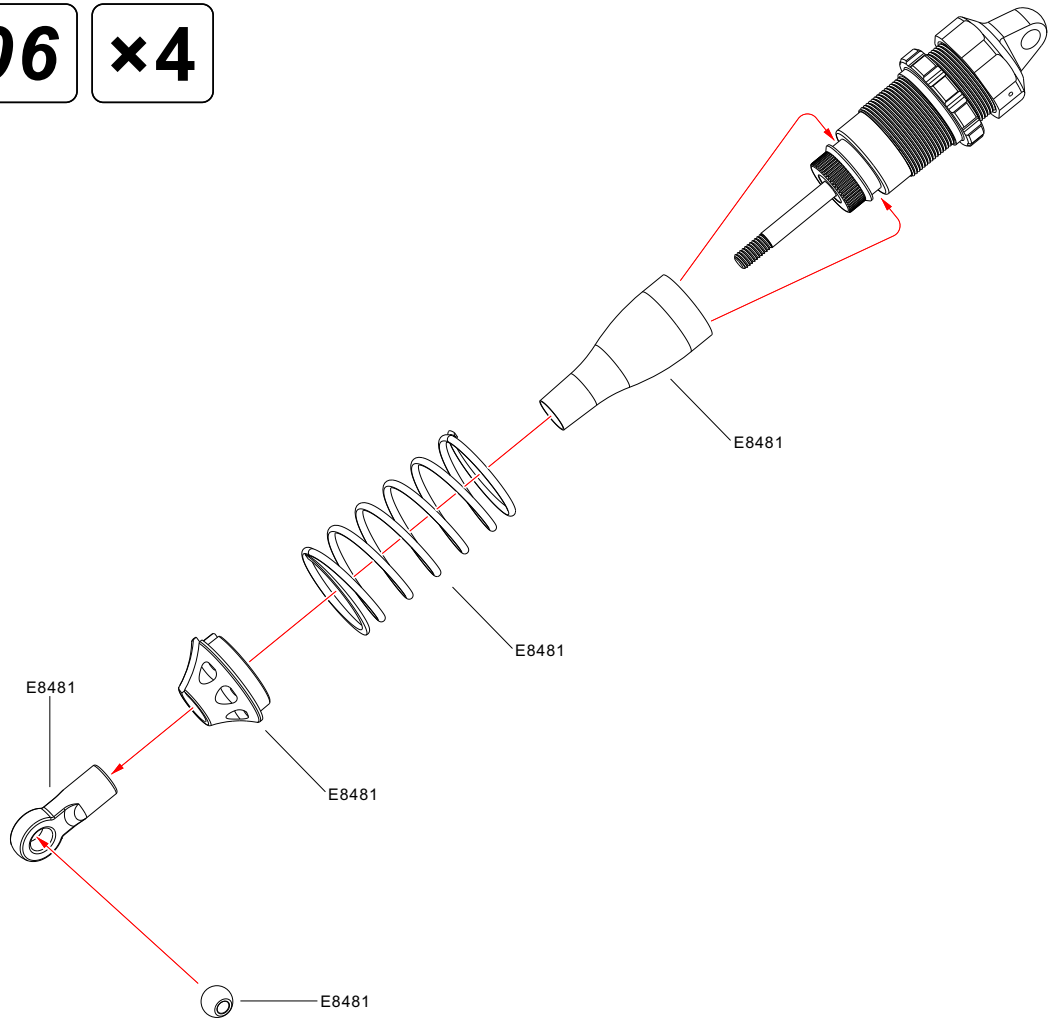

TC4012
M4×12mm

×4



TMS5004
机米螺丝M5×4mm

×2



TMN30N
M3薄螺母

×2

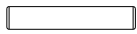

THP3017
钢销3×17mm

×2

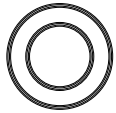

TBB081404
轴承8×14×4mm

×4

07 **L/R**

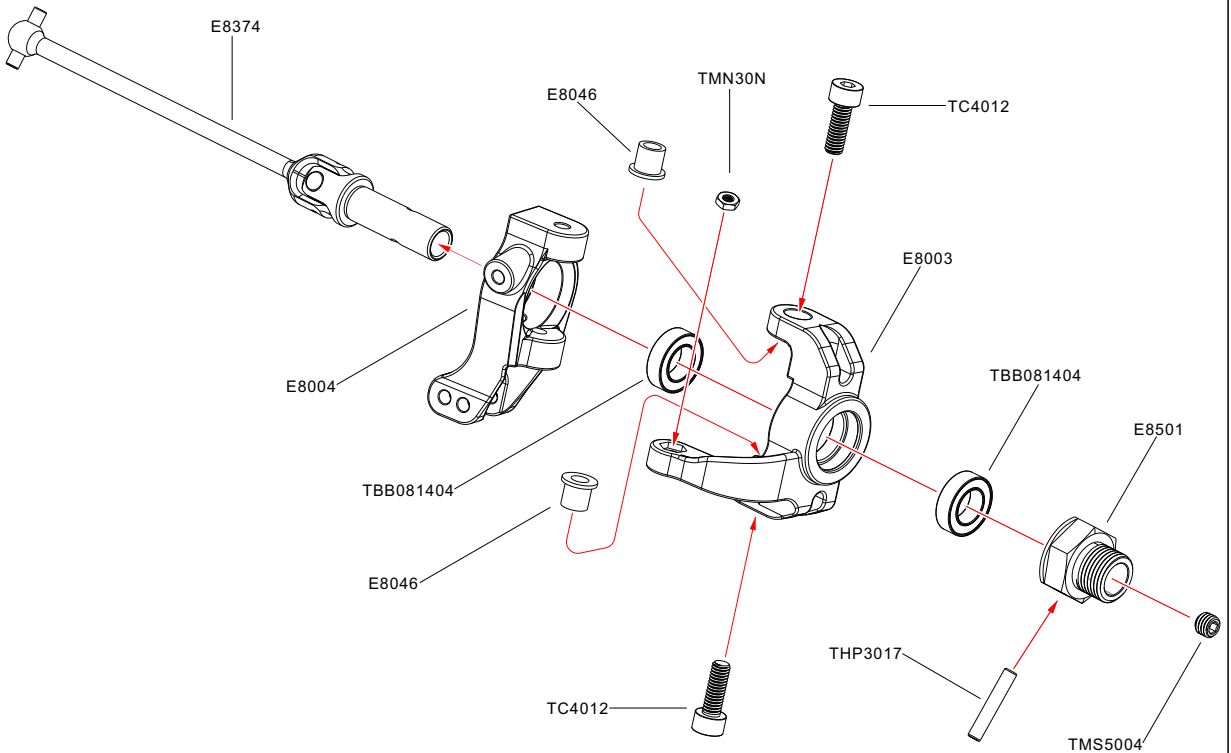

8

×2

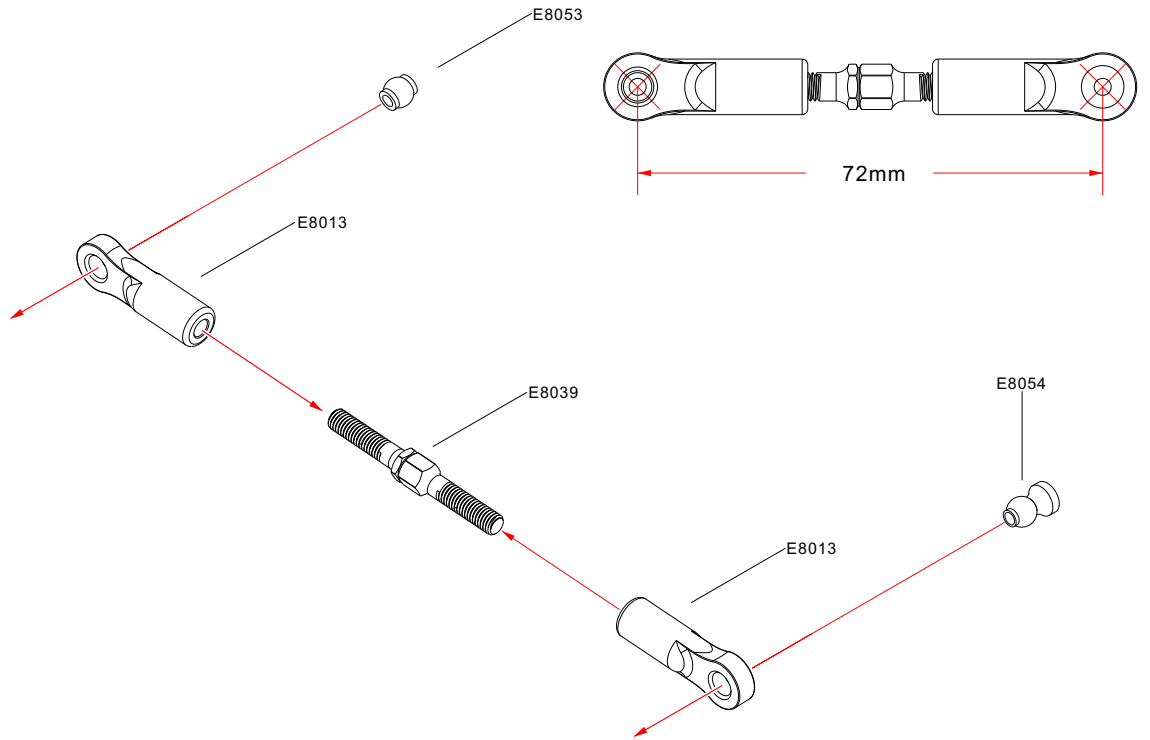

9

 TMS3003
Set Screw M3×3mm

×2

 TMS3008
Set Screw M3×8mm

×4

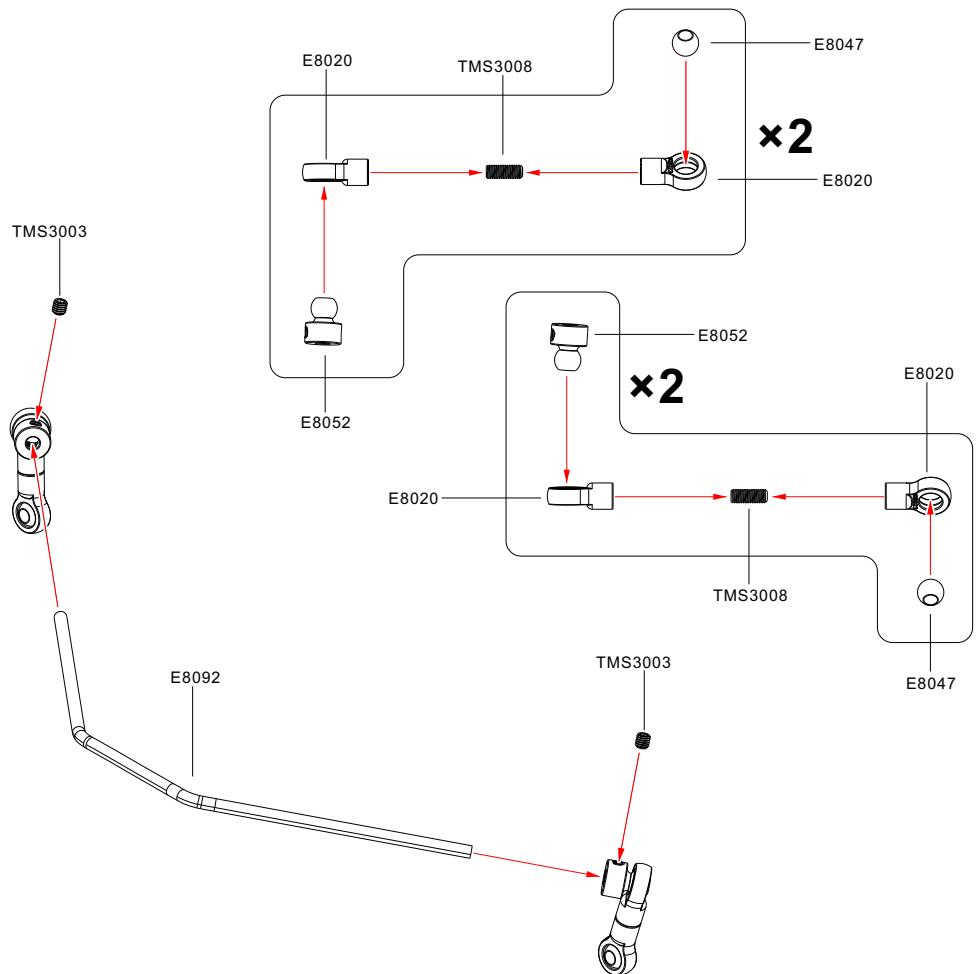

10 L/R



TB3006
M3×6mm

×4



TC3020
M3×20mm

×2



TMN30
M3 Nylon Nut

×2

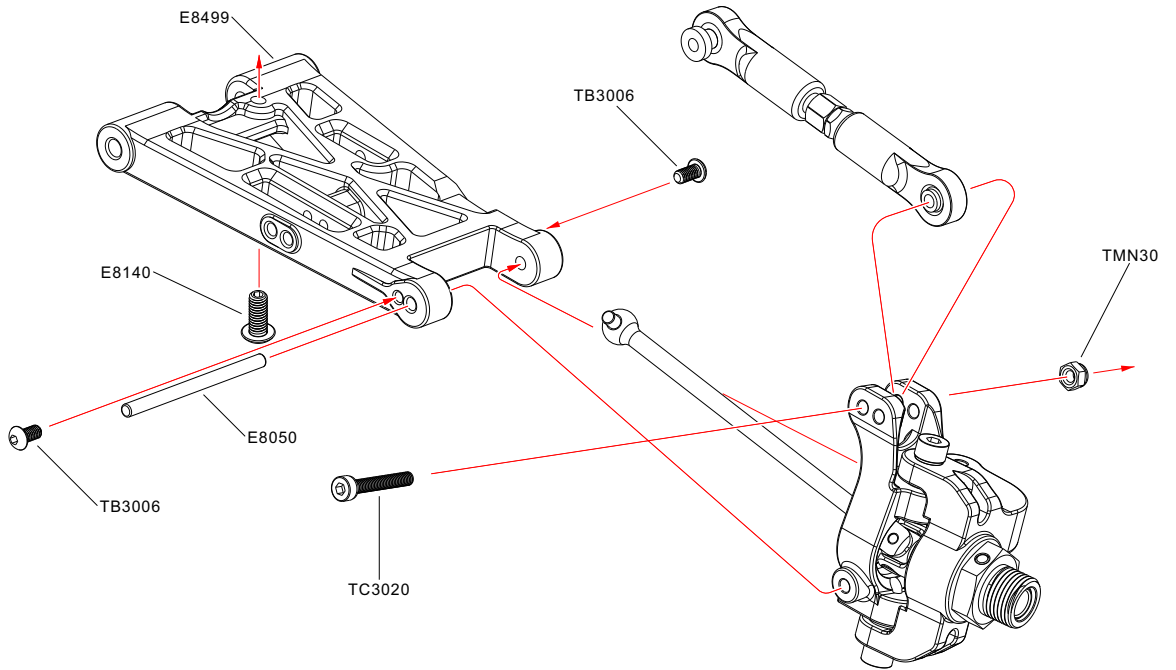
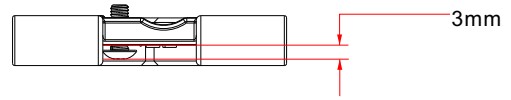

TB3004
M3×4mm

×2



TC3514
M3.5×14mm

×2

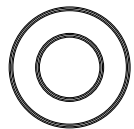

TBB081605
Bearing 8×16×5mm

×2

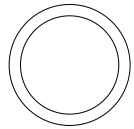

TW131602
Washer 13×16×0.2mm

×4

11

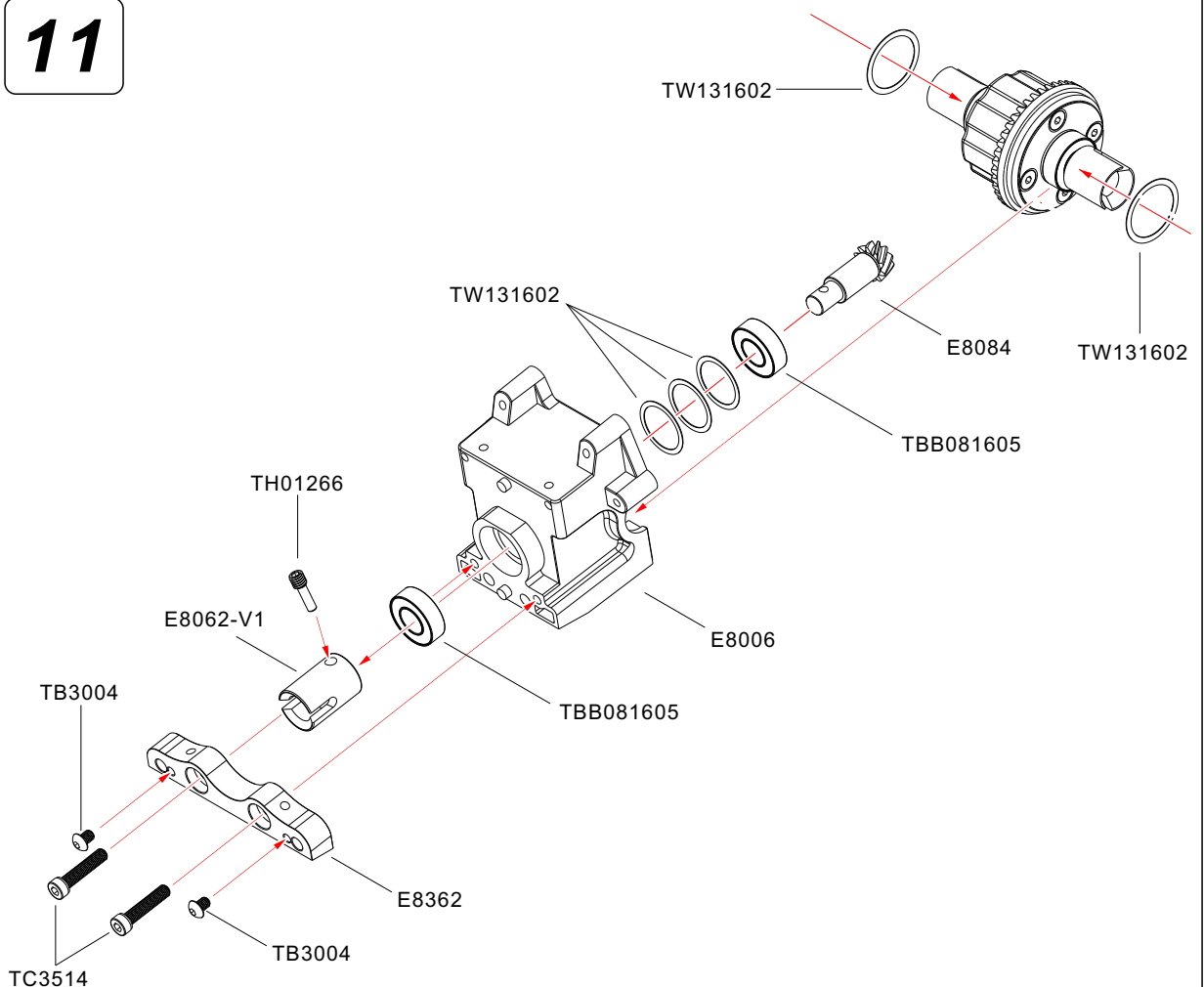

12



TC3518
M3.5×18mm

×2



TC3542
M3.5×42mm

×2

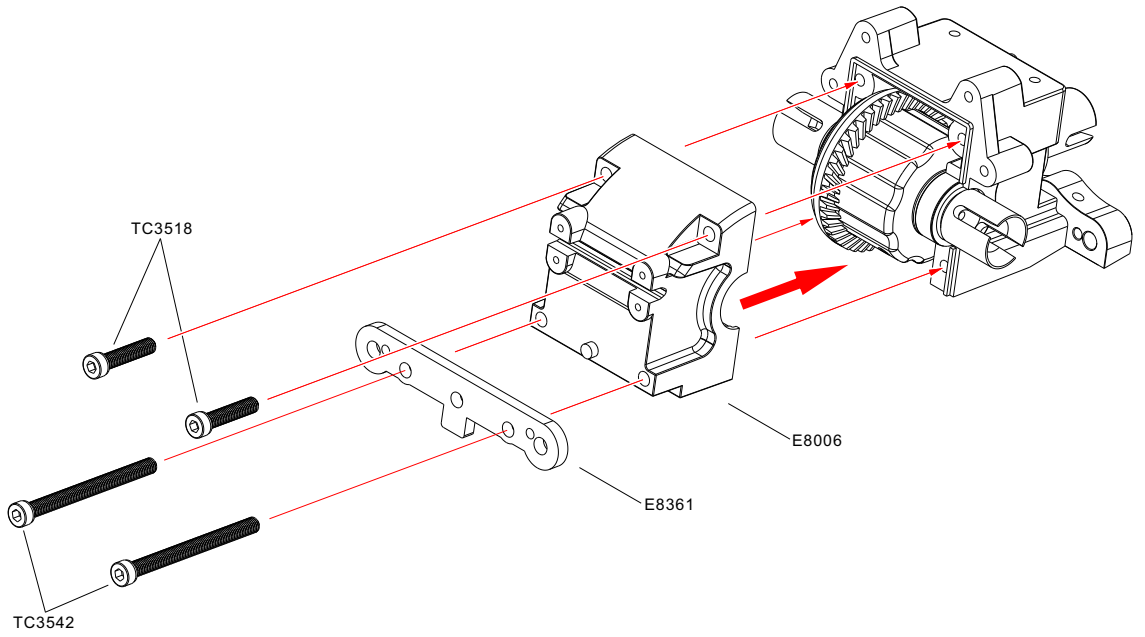

13



TB3014
M3×14mm

×4

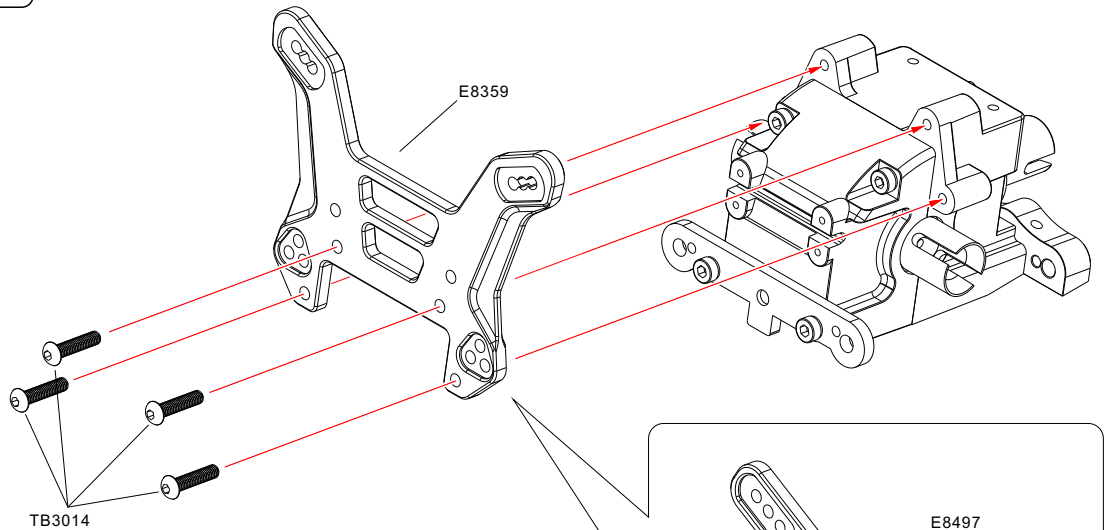

Optional part
Packed in the bag

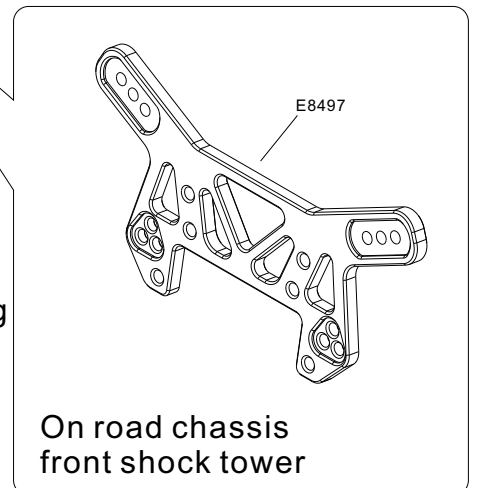

14



TB3004
M3×4mm

×2



TB3020
M3×20mm

×2



TMN30
M3 Nylon Nut

×2



TSP30
M3 Spring Washer

×2

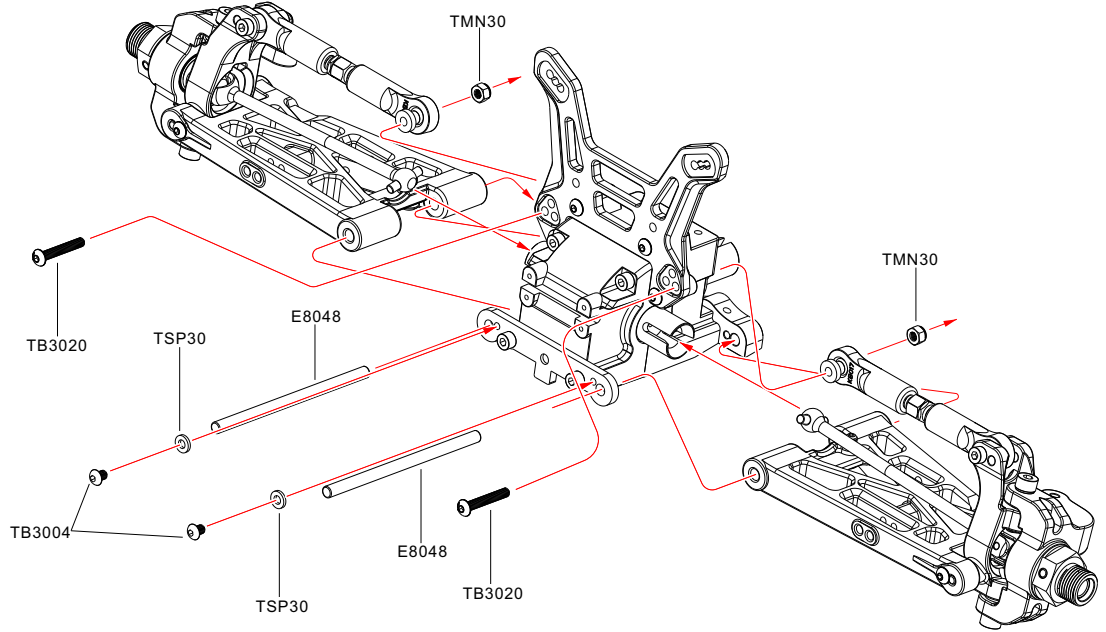

15



TC3016
M3×16mm

×2



TMS3005
Set Screw M3×5mm

×2



TBC2205
T.P. M2.2×5mm

×4

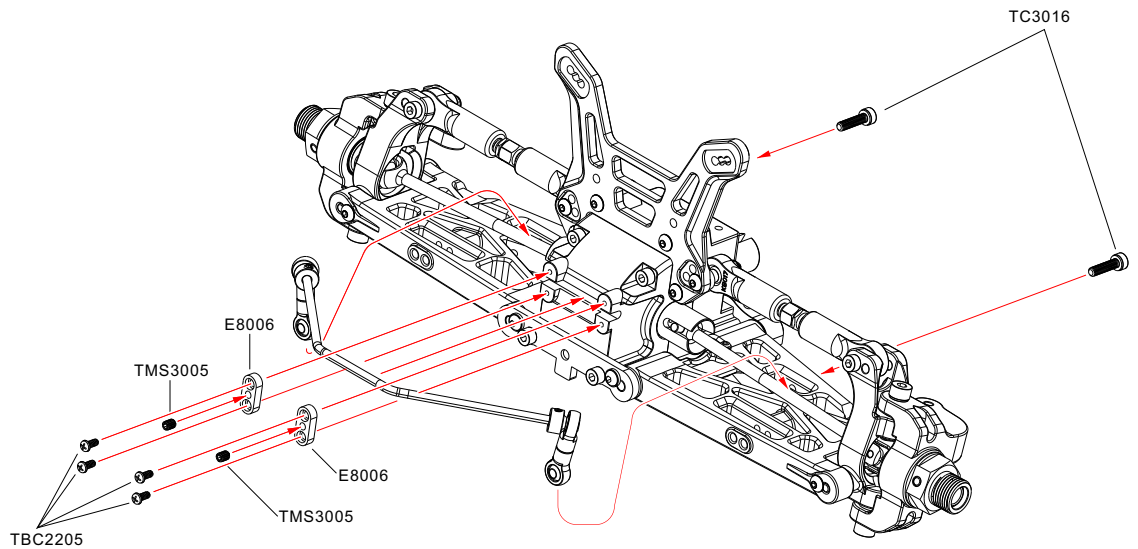

16



TB3020
M3×20mm

×2



TC3022
M3×22mm

×2



TMNF30
M3 Flanged Nylon Nut

×2

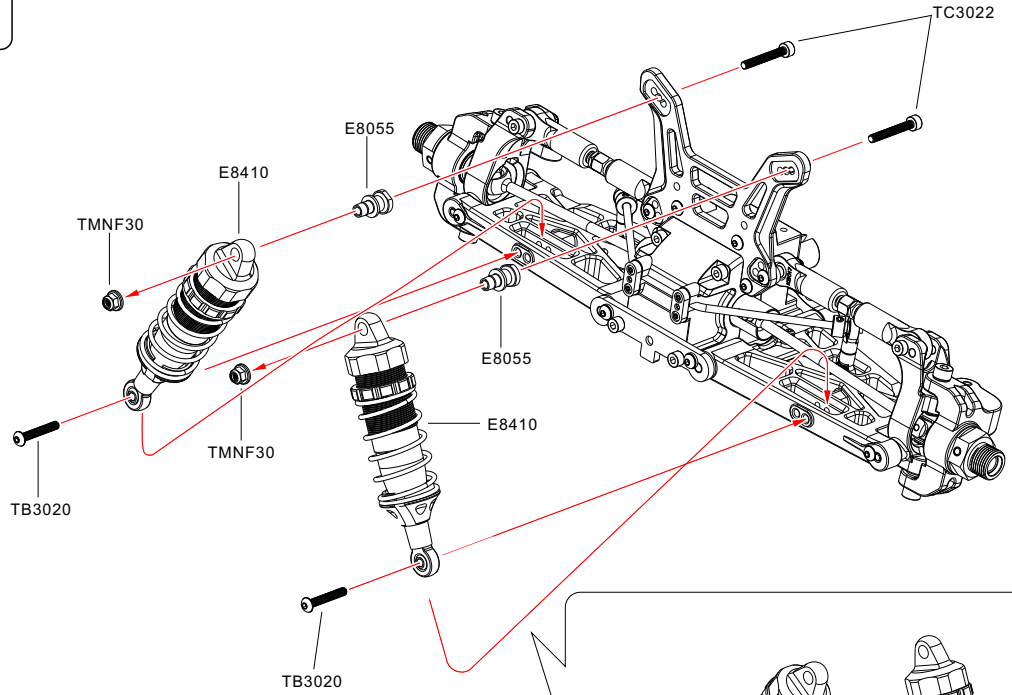

Optional part
Packed in the bag

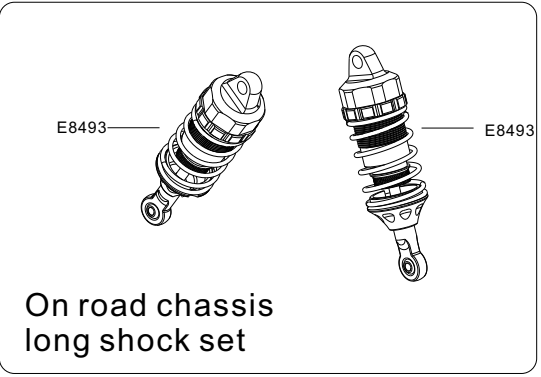

17



TF3010
M3×10mm

×3



TMN40
M4 Nylon Nut

×1

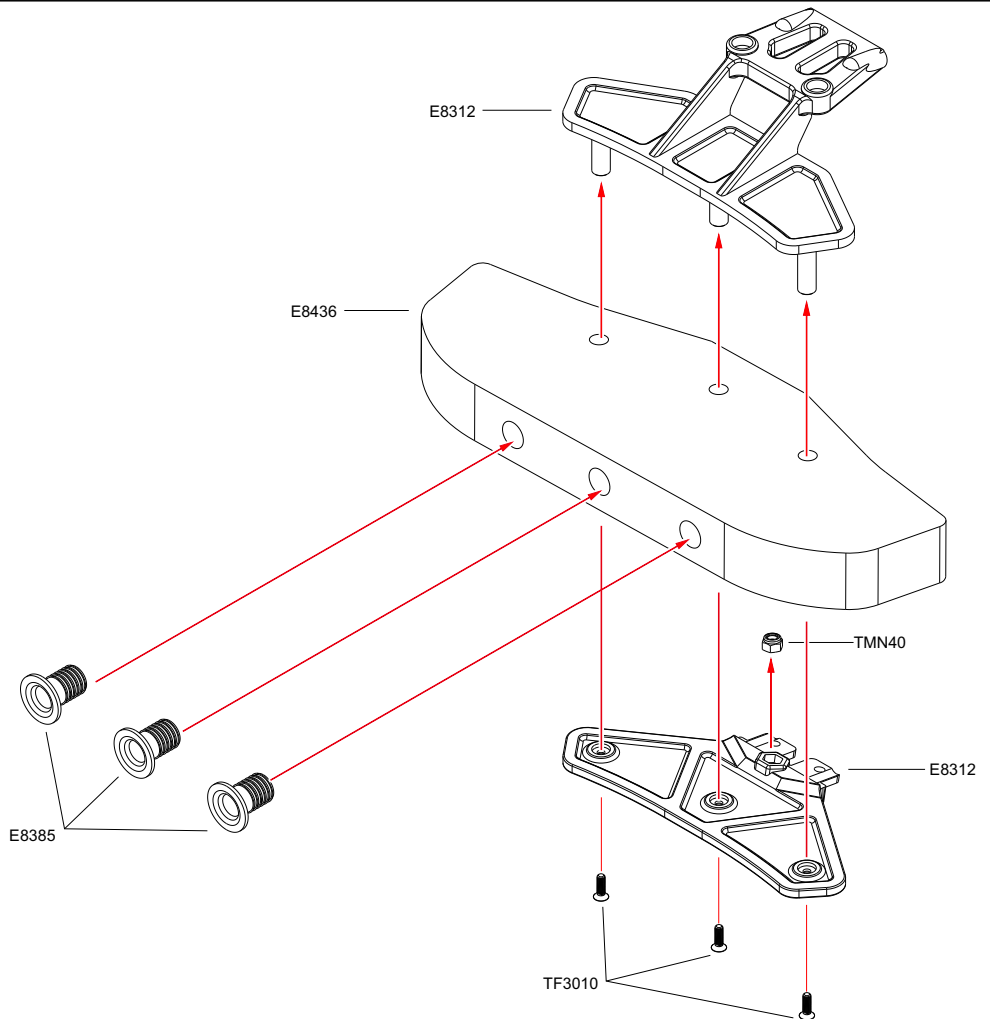

18



TB3010
M3×10mm

×2

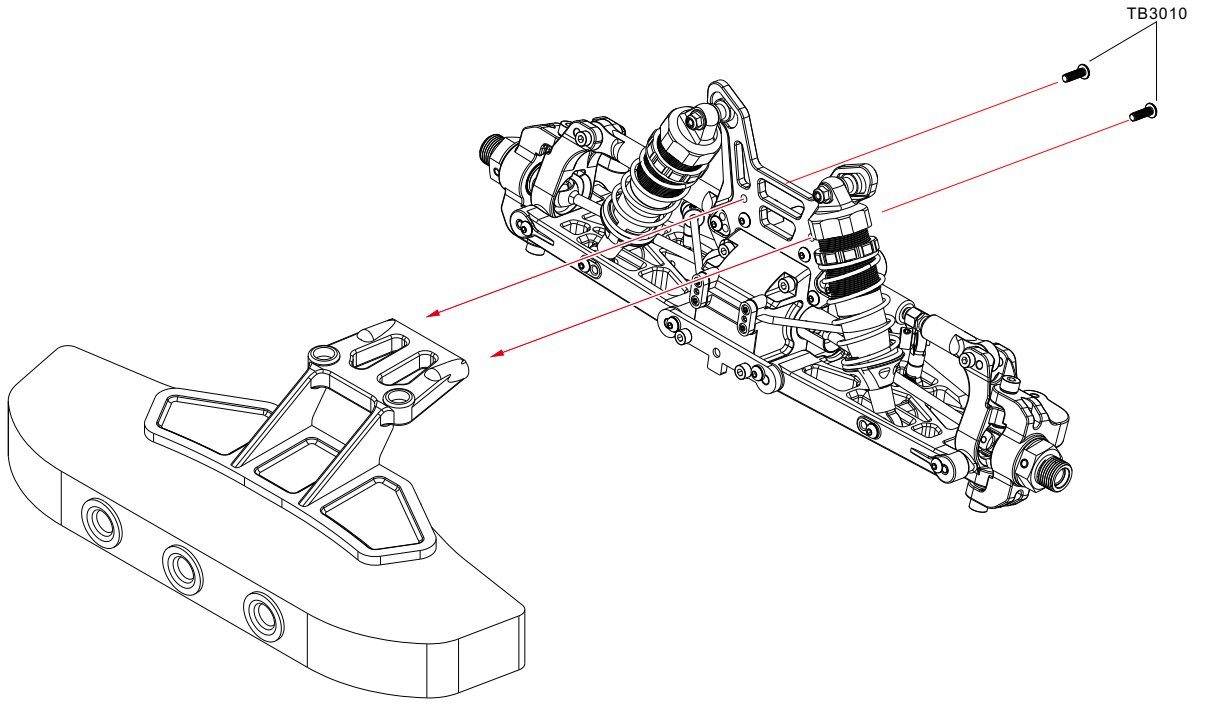

19



TMS3003
Set Screw M3×3mm

×2

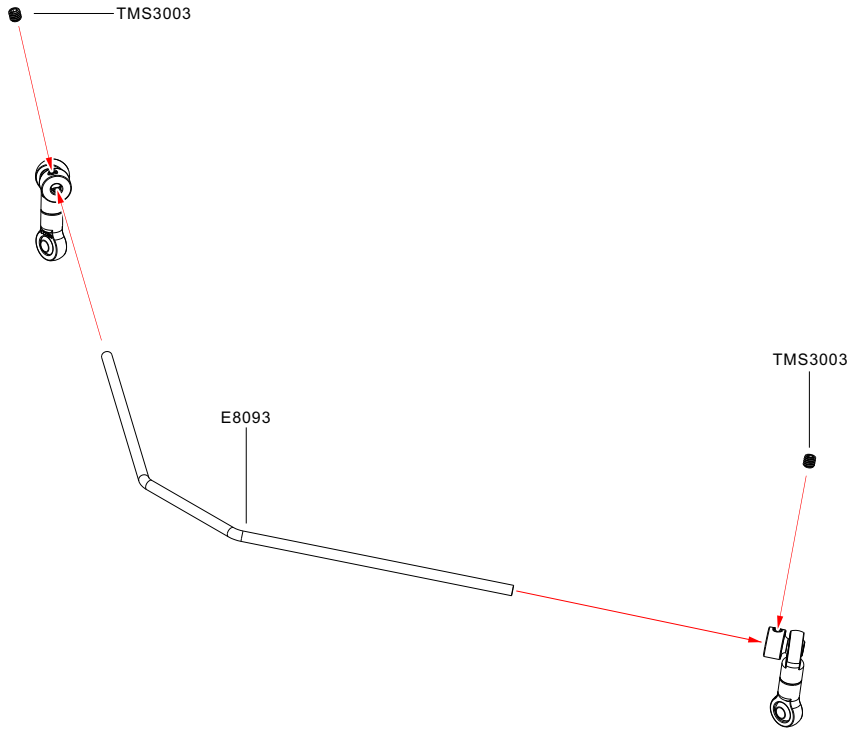

20 **×2**

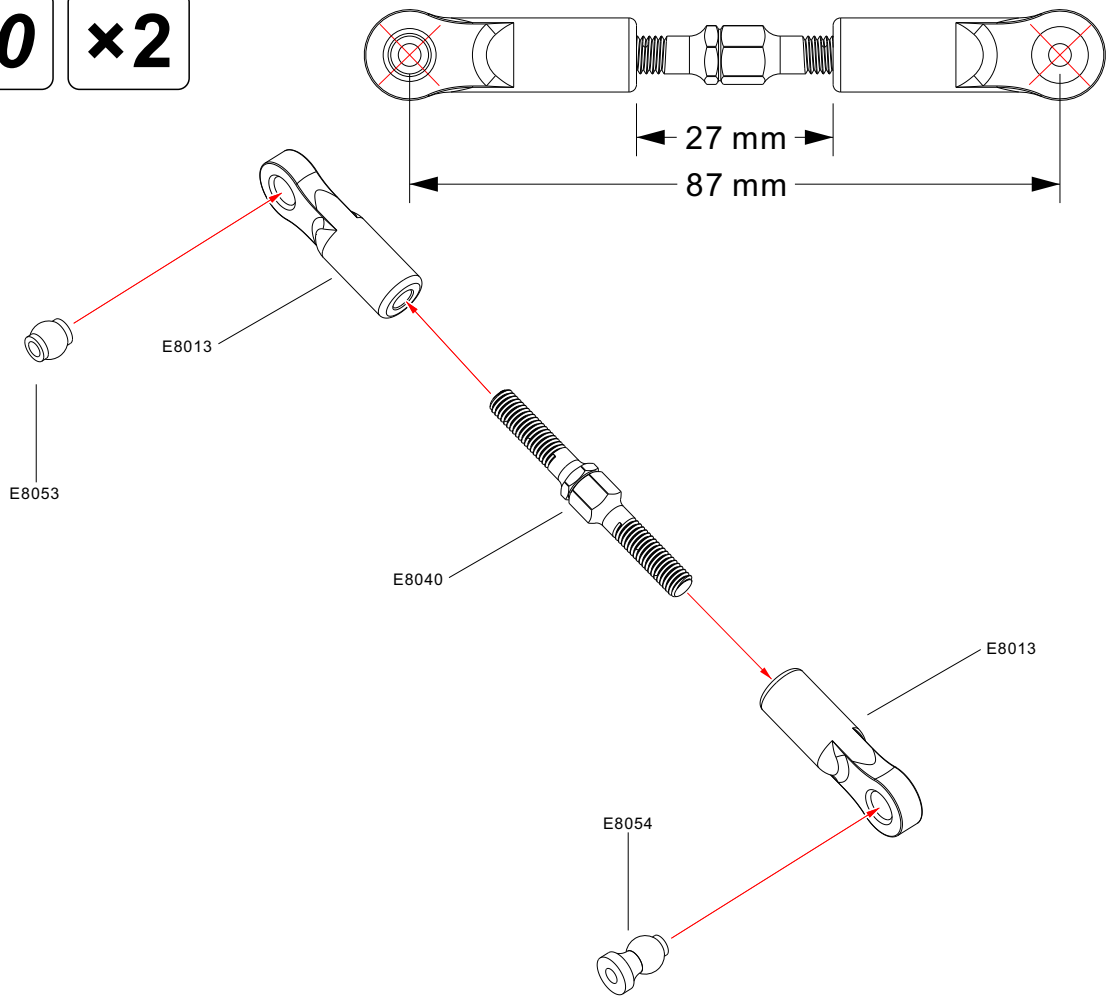

21 **L/R**



TC3020
M3×20mm ×2



TMS5004
Set Screw M5×4mm ×2



TMN30
M3 Nylon Nut ×2

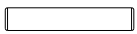

THP3017
PIN 3×17mm ×2

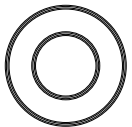

TBB081605
Bearing 8×16×5mm ×4

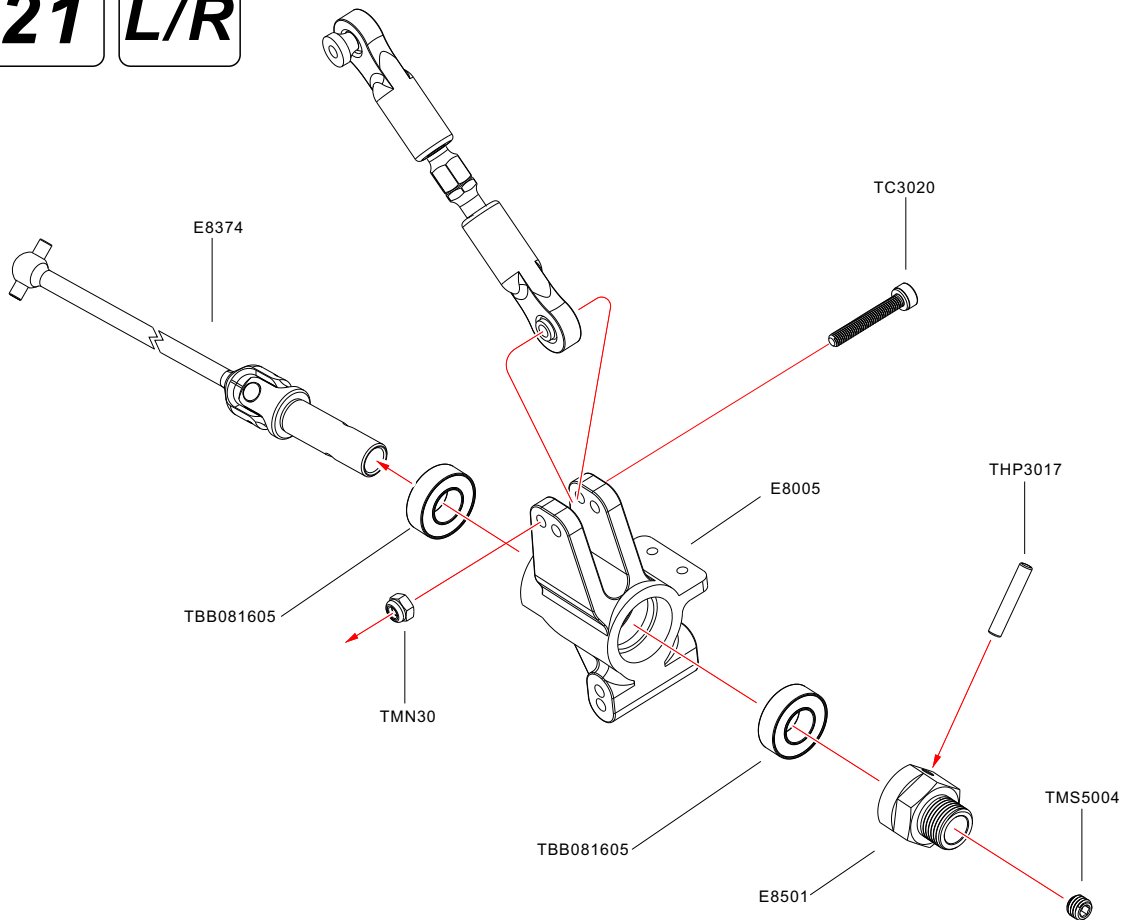

22 L/R



TB3006
M3×6mm

×4

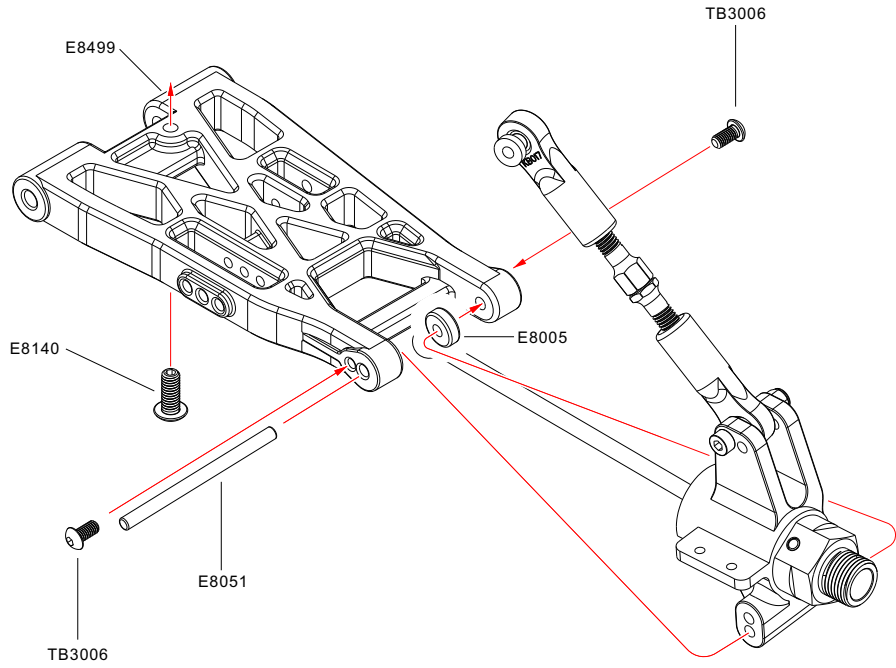
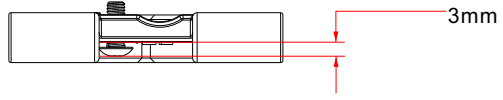

23



TB3004
M3×4mm

×2



TC3514
M3.5×14mm

×2



TW320810
Washer 3.2×8×1mm

×2

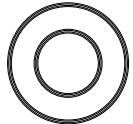

TBB081605
Bearing 8×16×5mm

×2

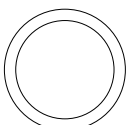

TW131602
Washer 13×12×0.2mm

×2

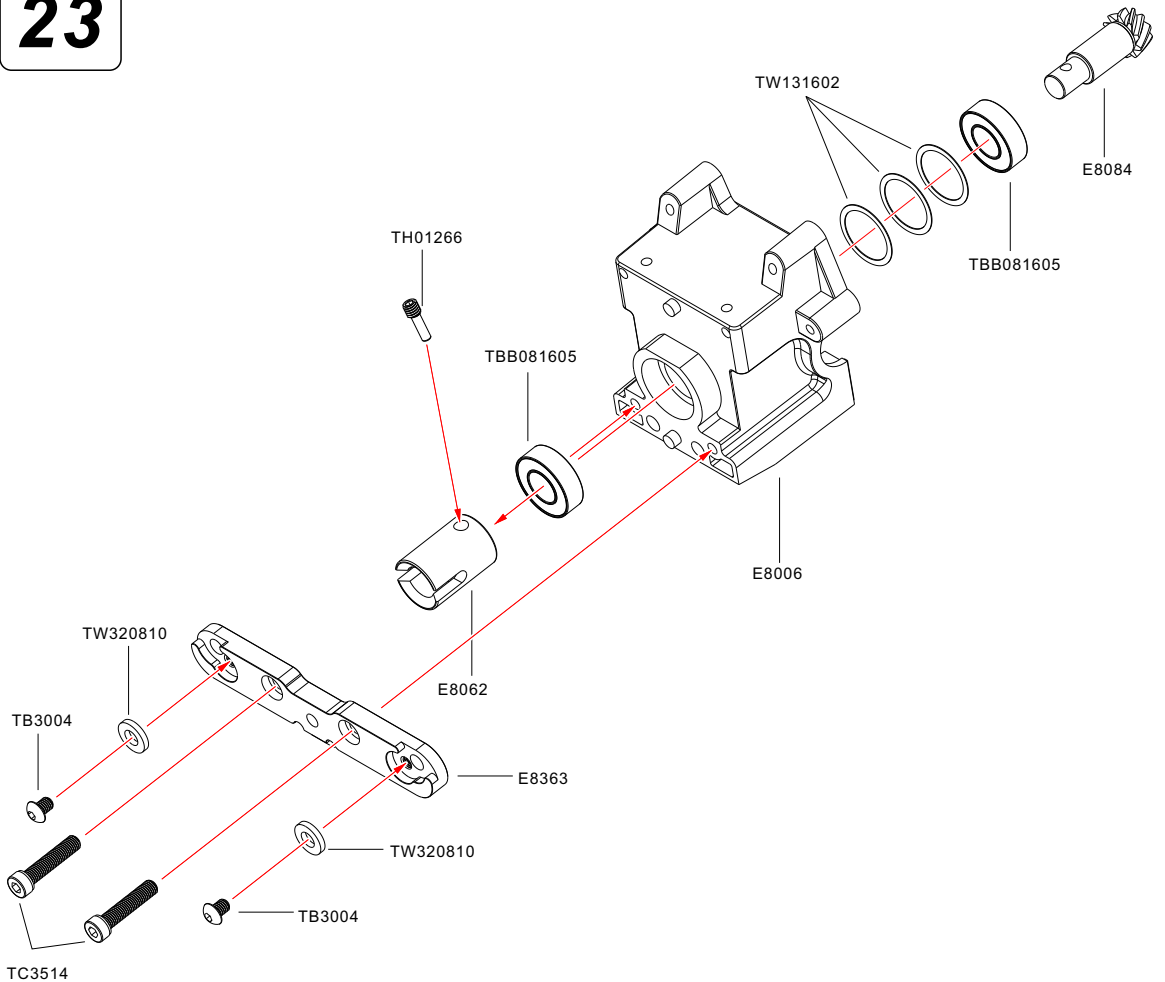

24



TC3518
M3.5×18mm

×2

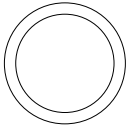

TW131602
Washer 13×12×0.2mm

×2

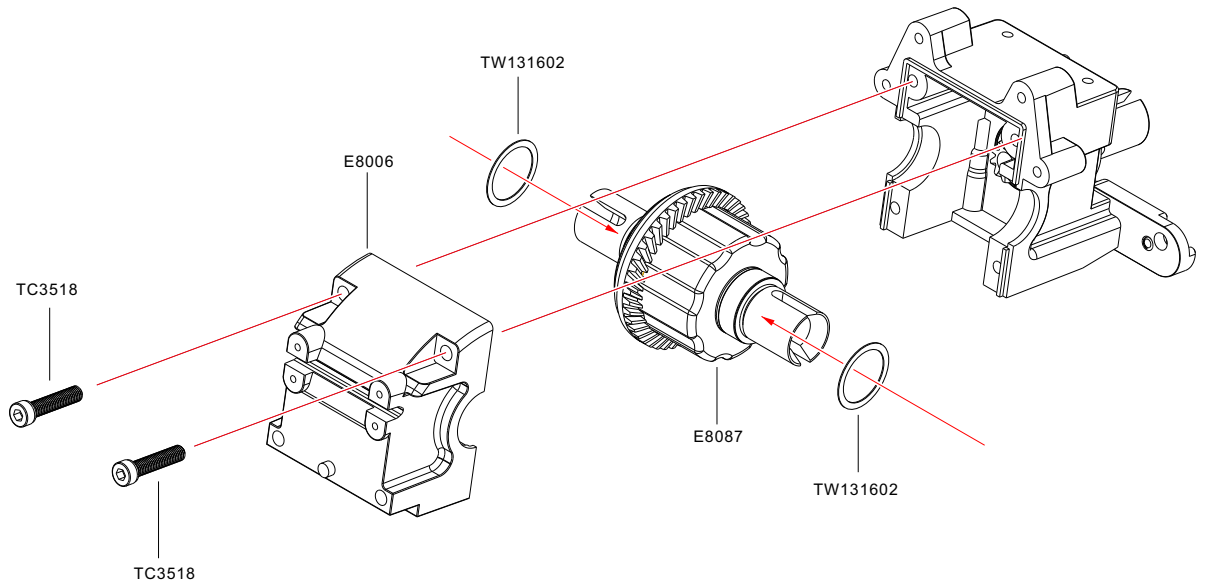

25



TB3014
M3×14mm

×2

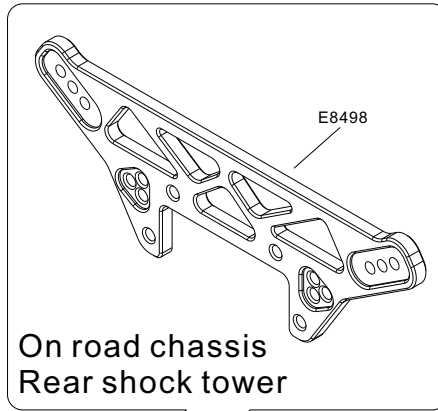

Optional part
Packed in the bag

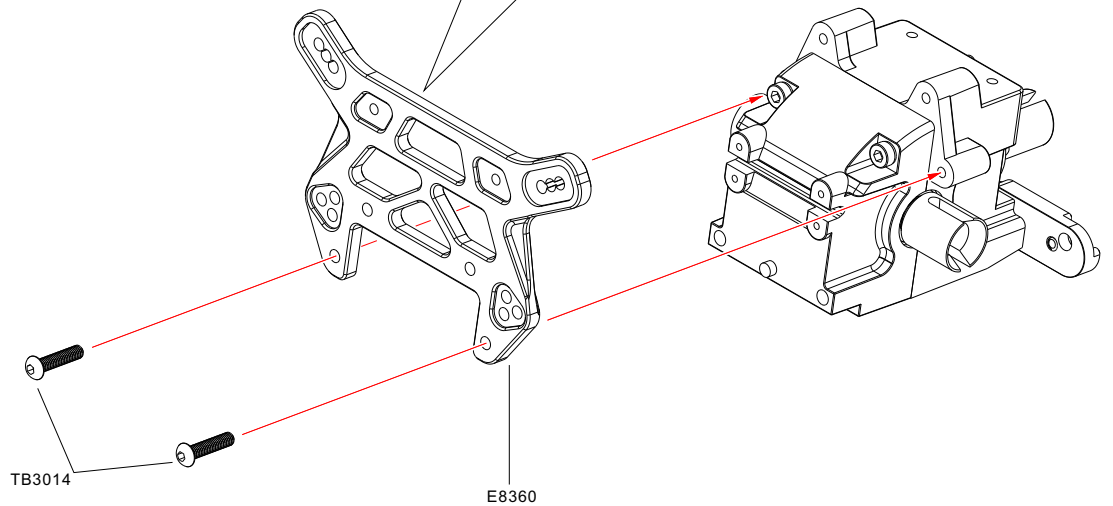

TB3004
M3×4mm ×2

TB3020
M3×20mm ×2

TMS3003
Set Screw M3×3mm ×2

TMN30
M3 Nylon Nut ×2

TW320810
Washer 3.2×8×1mm ×2

TW041003
Washer 4×10×0.3mm ×2

TC3542
M3.5×42mm ×2

TC3014
M3×14mm ×2

TMS3005
Set Screw M3×5mm ×2

TBC2205
T.P. M2.2×5mm ×4

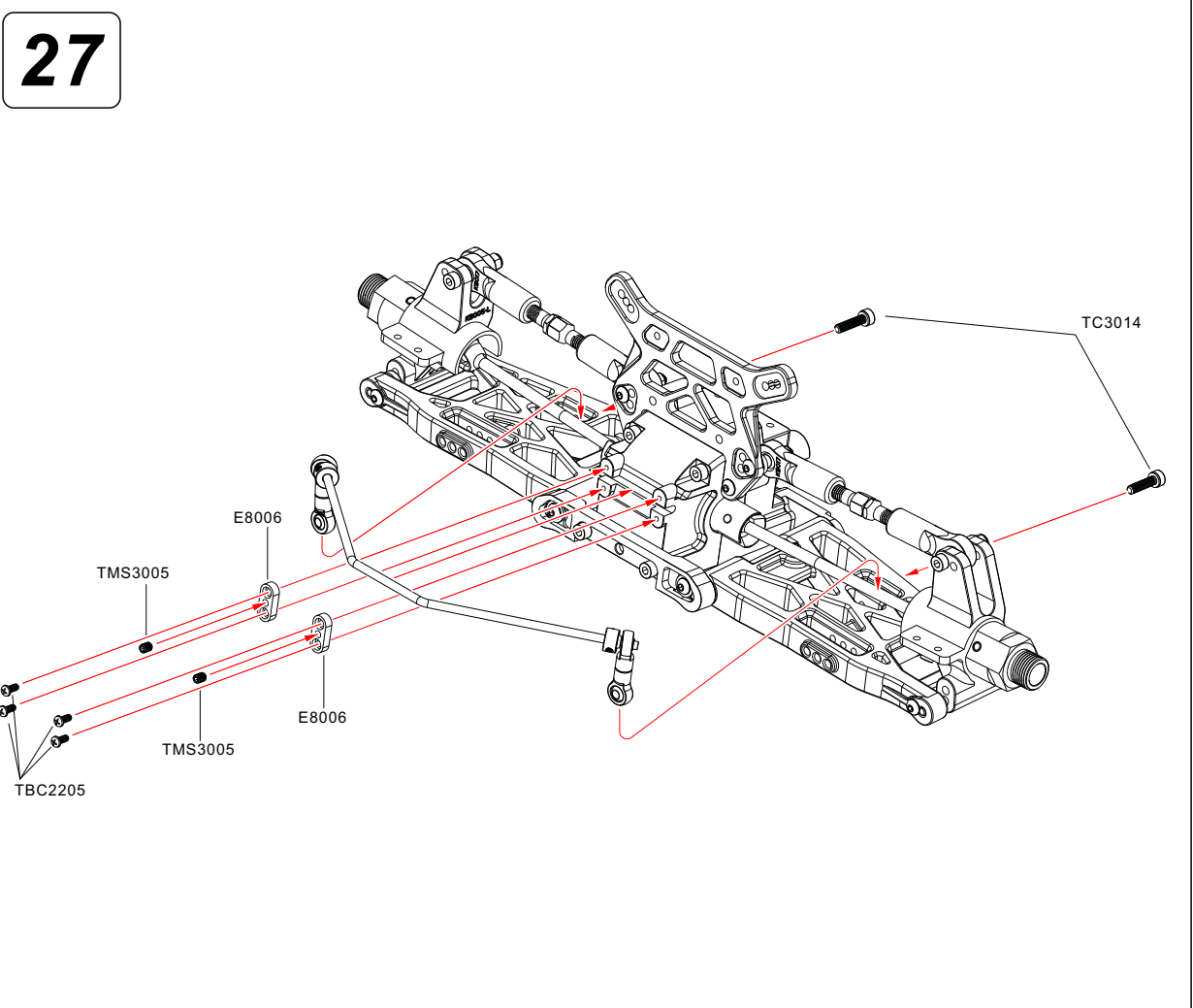
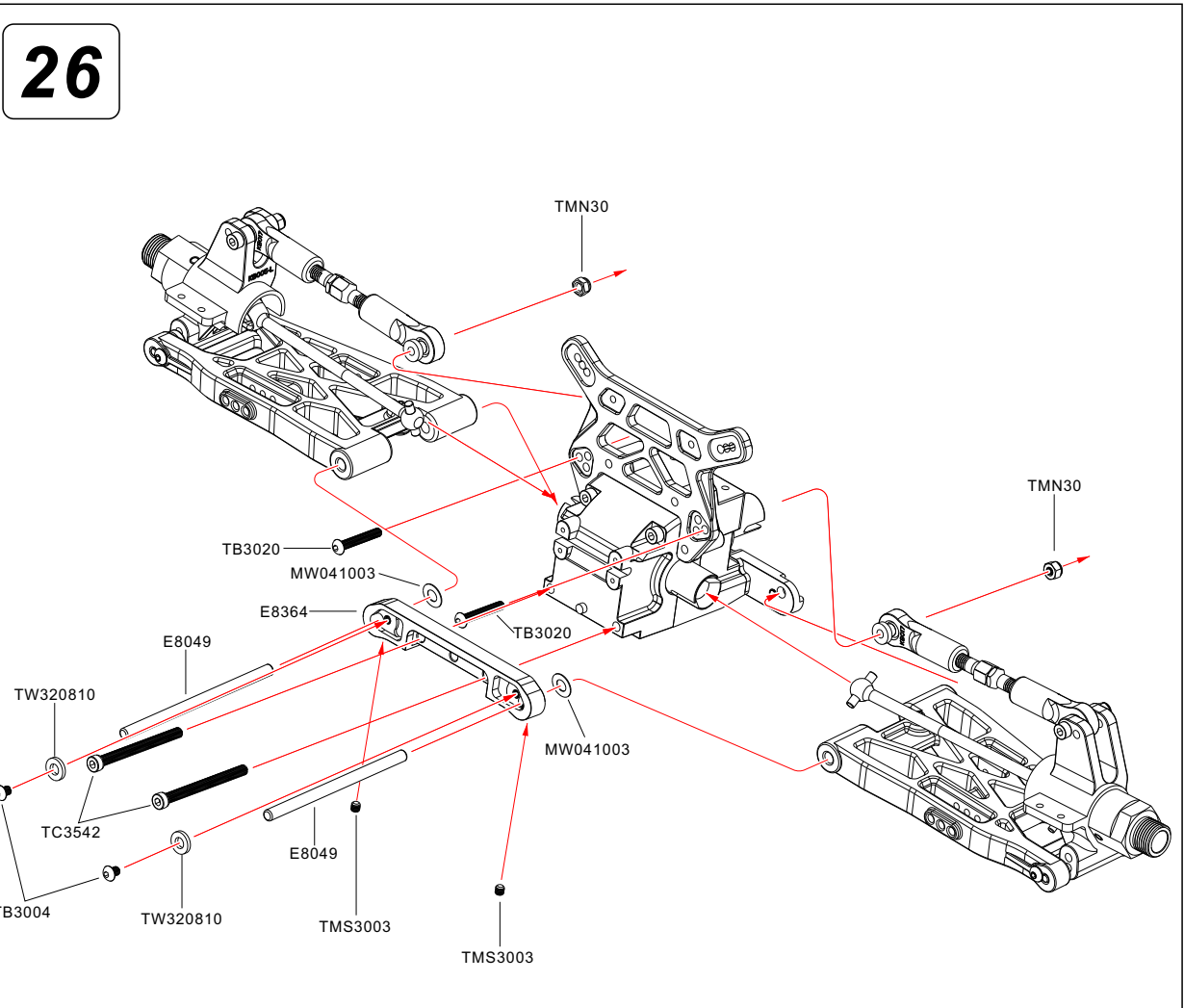

28



TB3020
M3×20mm ×2



TC3022
M3×22mm ×2



TMNF30
M3 Flanged Nylon Nut ×2

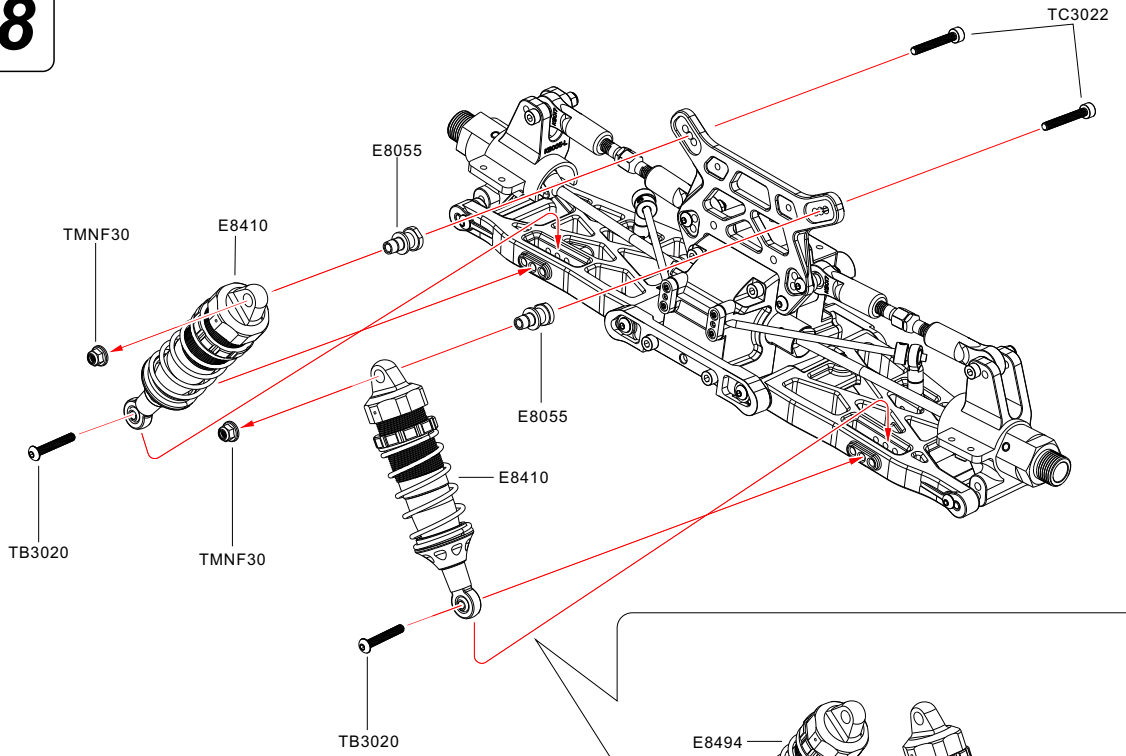

Optional part
Packed in the bag

On road chassis
short shock set

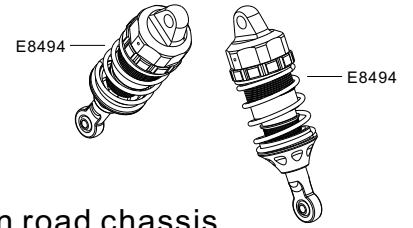

29

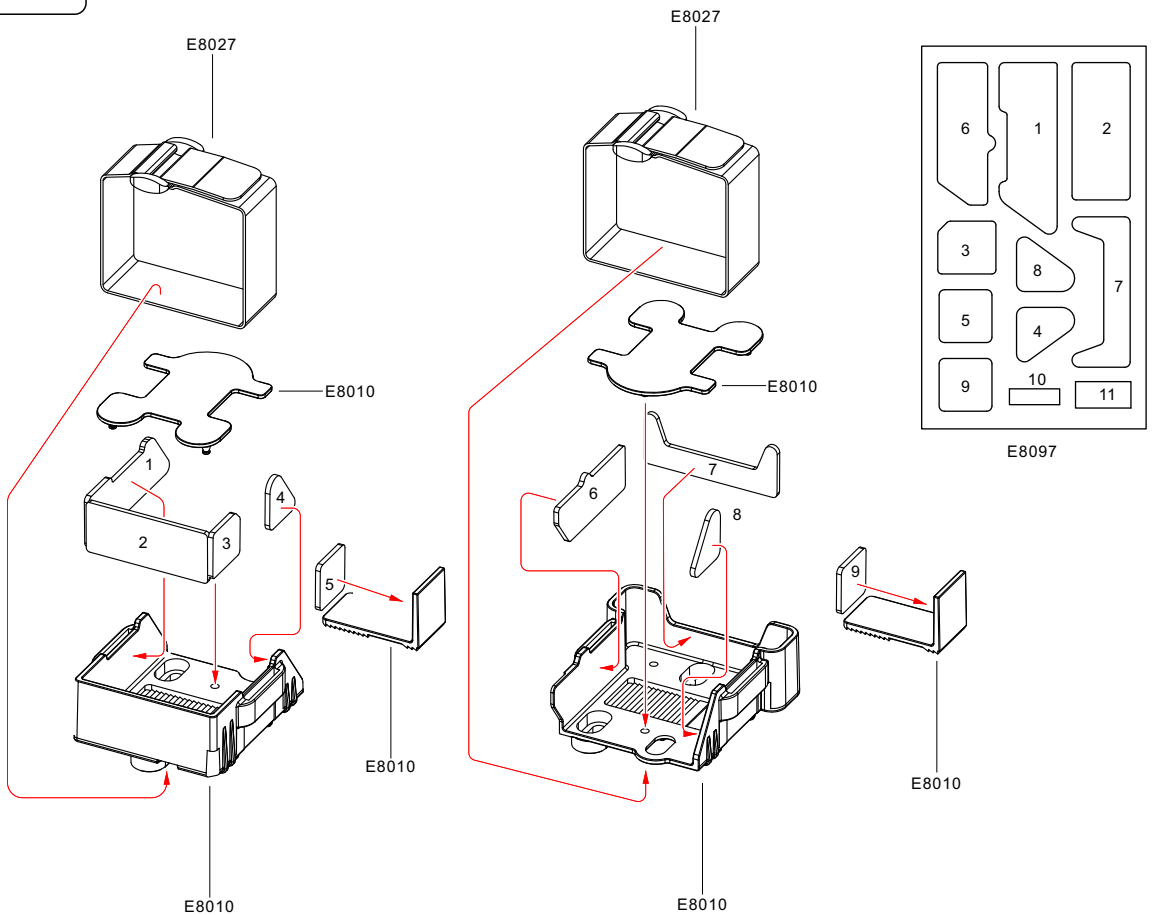

30

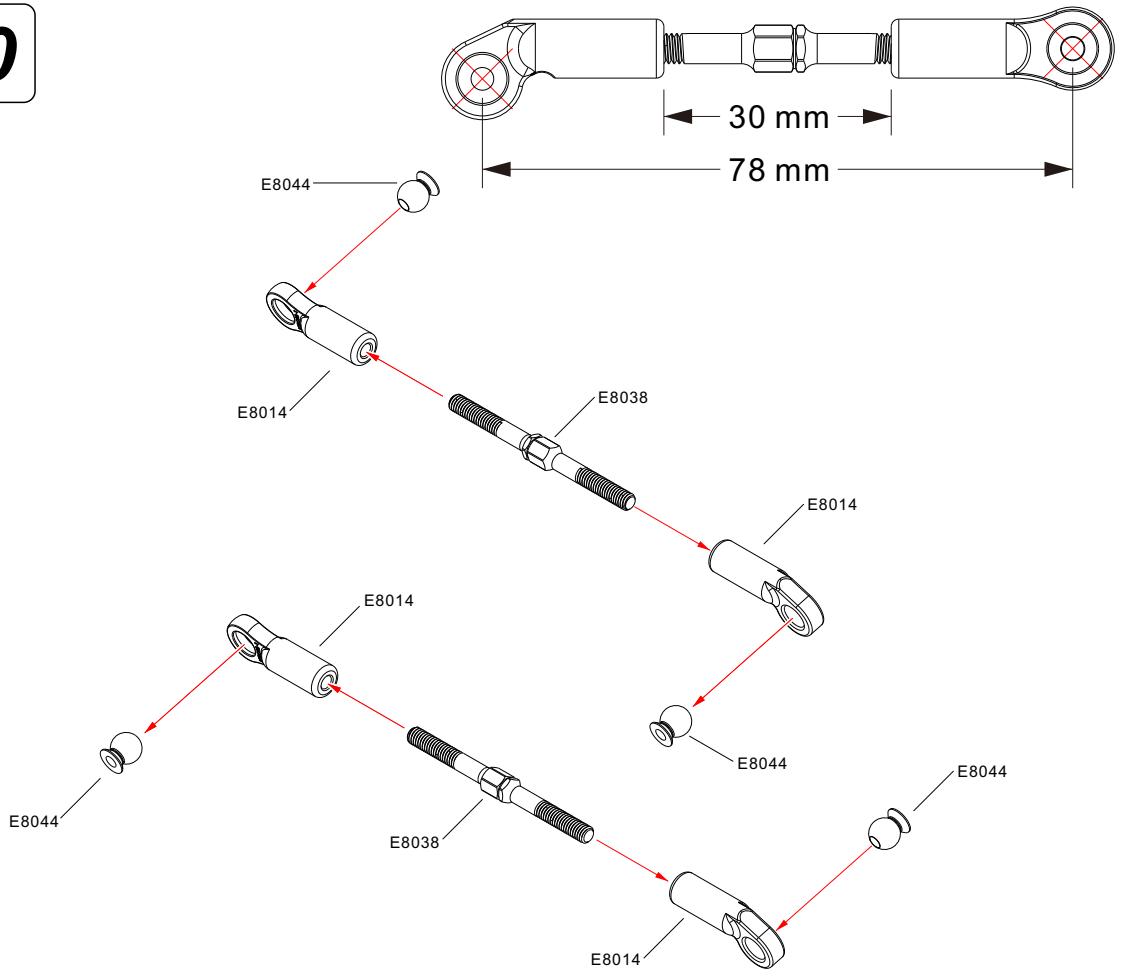

31

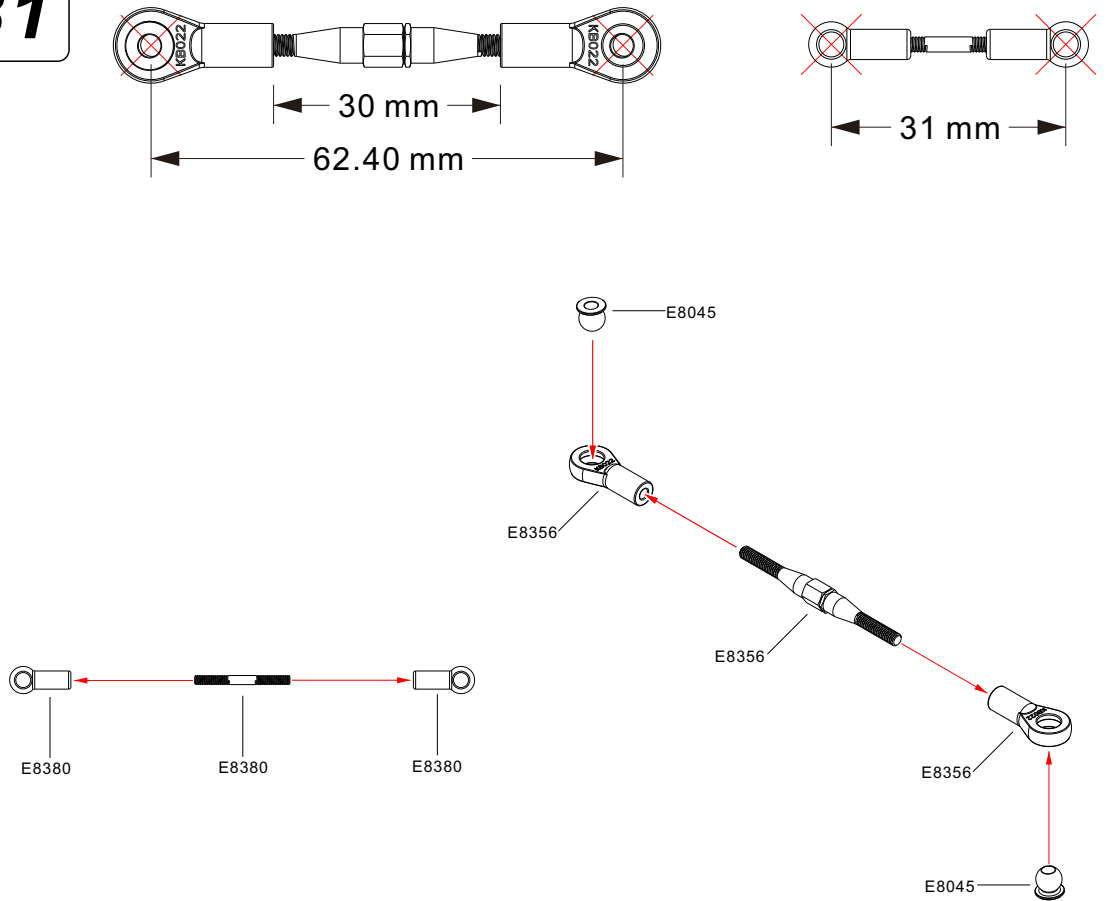

32



TBB061003
Bearing 6x10x3mm

×4

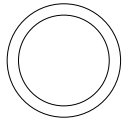

TRD15015
O-ring D15x1.5mm

×1

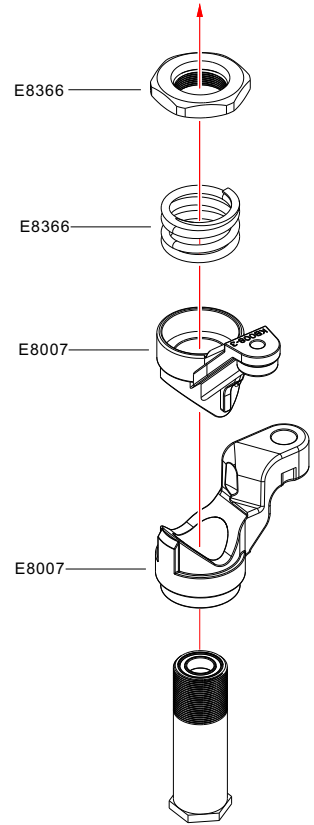
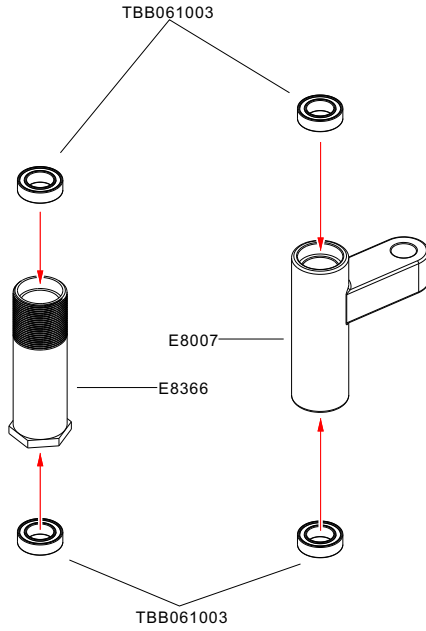
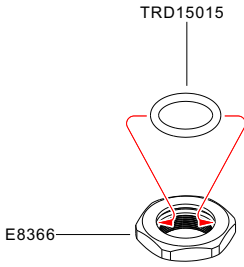
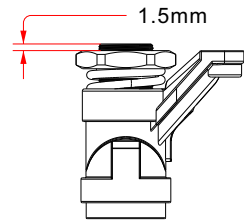

33



TF3020
M3x20mm

×2



TMN30
M3 Nylon Nut

×2

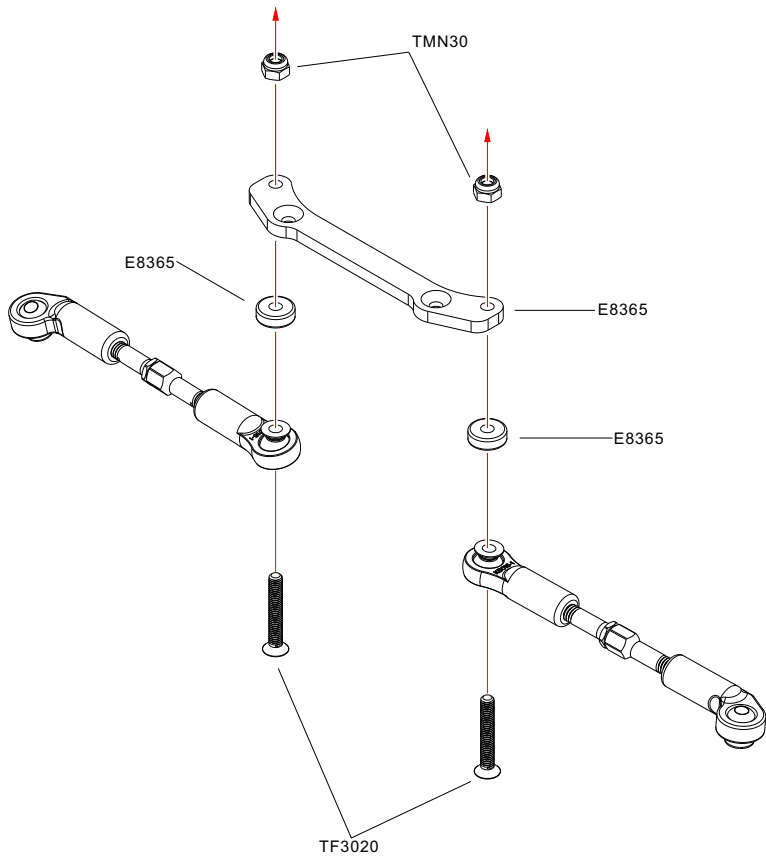

34



TB3012
M3×12mm

×1



TF3012
M3×12mm

×2



TB3014
M3×14mm

×1



TMN30
M3 Nylon Nut

×2

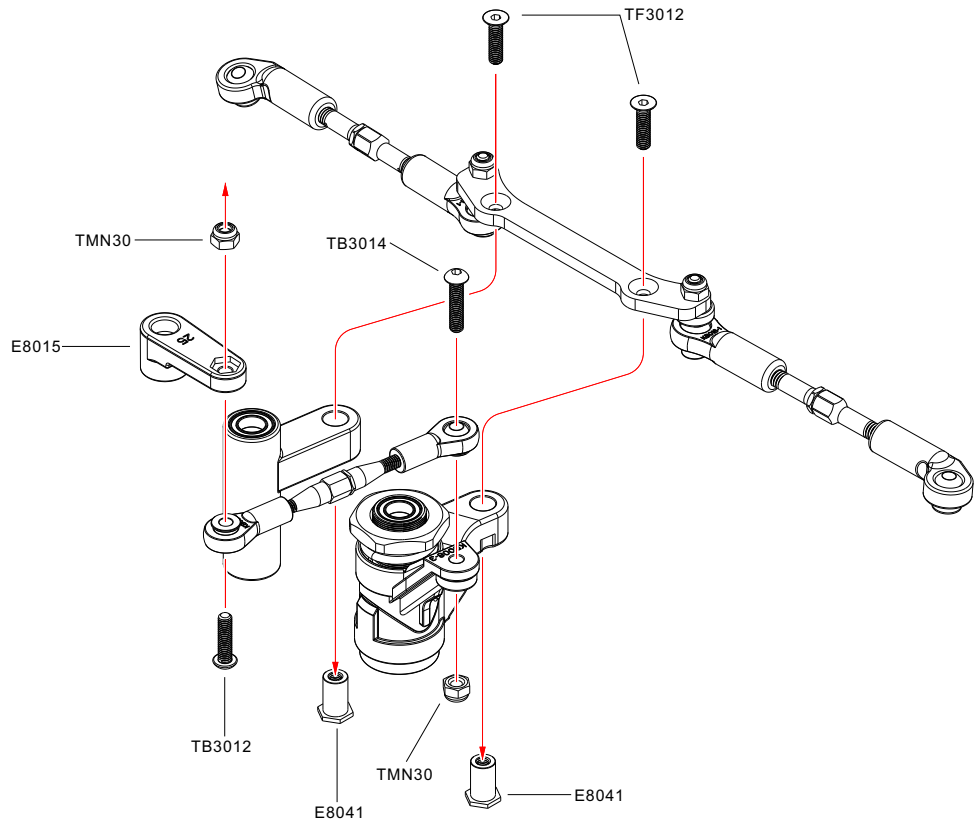

35



TC3014
M3×14mm

×1

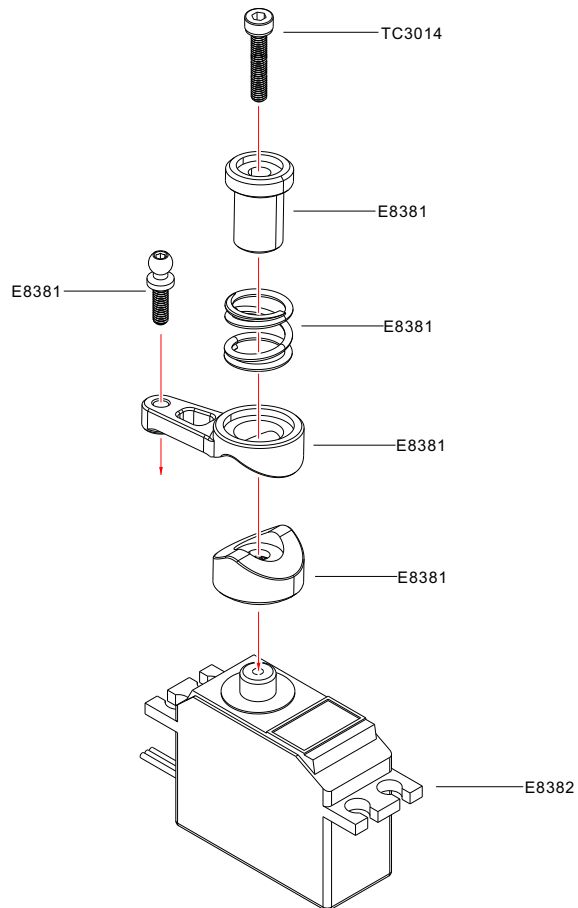

36



TB3006
M3×6mm

×8



TW030705
Washer 3×7×0.5mm

×4



TW320810
Washer 3.2×8×1mm

×4

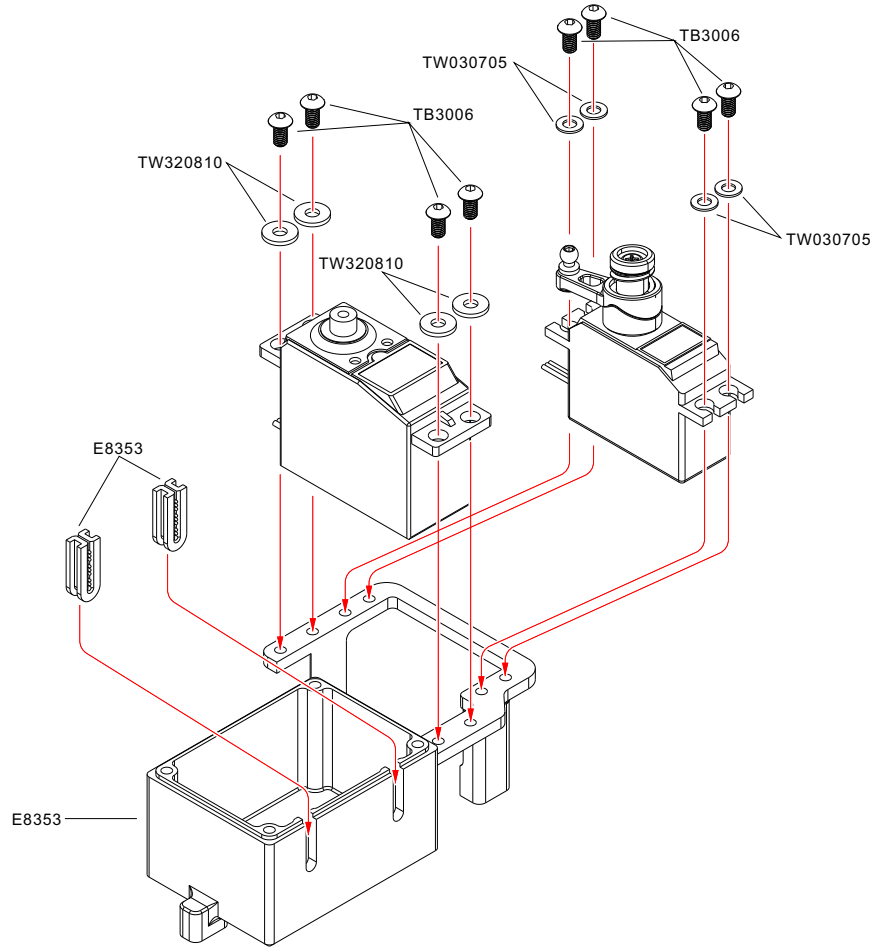

37



TB3006
M3×6mm

×4

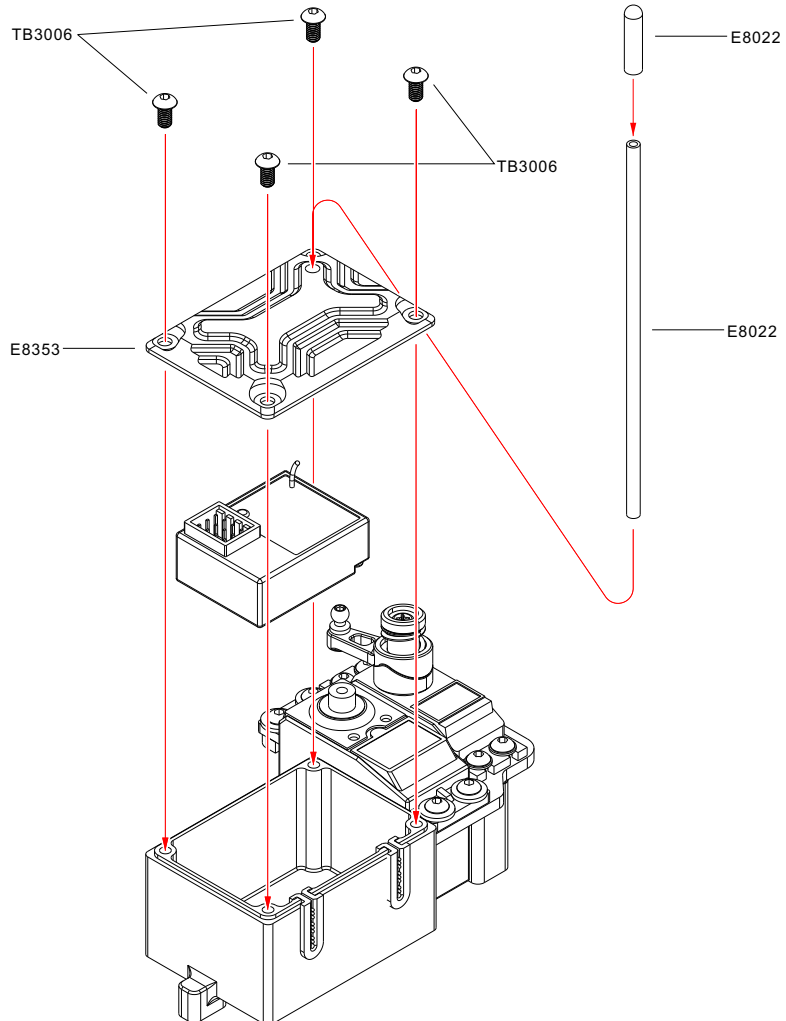

38

-  THP2514
PIN 2.5x14mm ×1
-  TW041003
Washer 4x10x0.3mm ×4
-  TW061605
Washer 6x16x0.5mm ×1
-  TRD10020
O-ring D10x2mm ×1
-  TRD05005
O-ring D5x0.5mm ×1

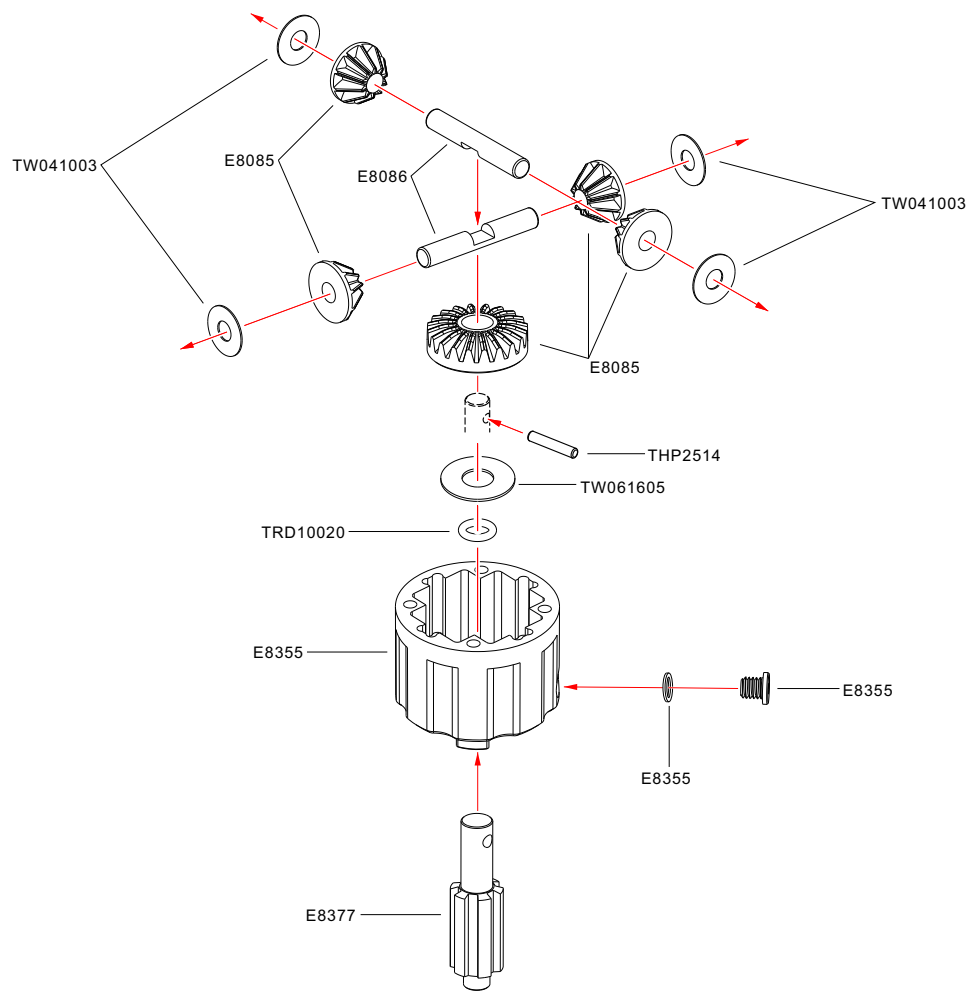

39

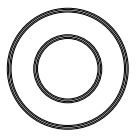
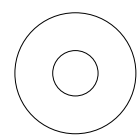
-  TB3010
M3x10mm ×4
-  THP2514
PIN 2.5x14mm ×1
-  TRD10020
O-ring D10x2mm ×1
-  TBB081605
Bearing 8x16x5mm ×1
-  TW061601
Washer 6x16x0.1mm ×3
-  TW061605
Washer 6x16x0.5mm ×1

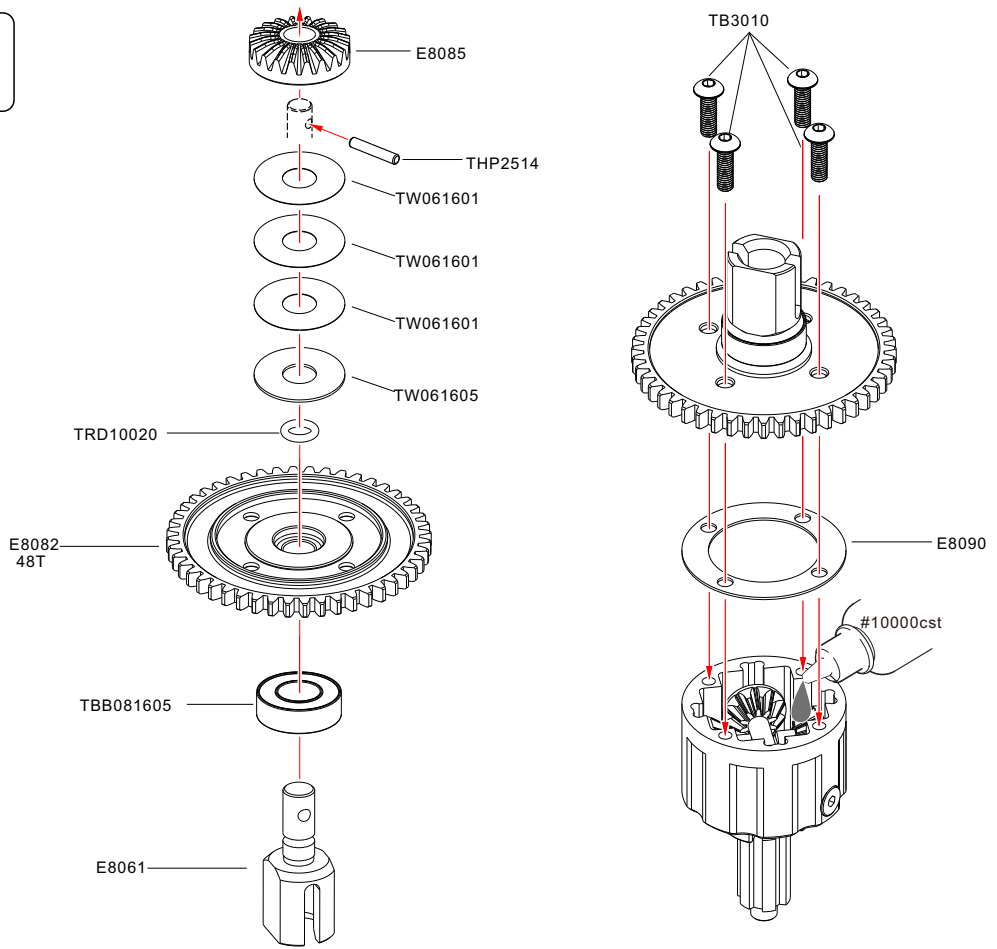

40



TB3008
M3×8mm

×4

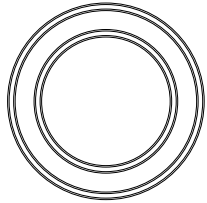

TBB172605
Bearing 17×26×5mm

×1

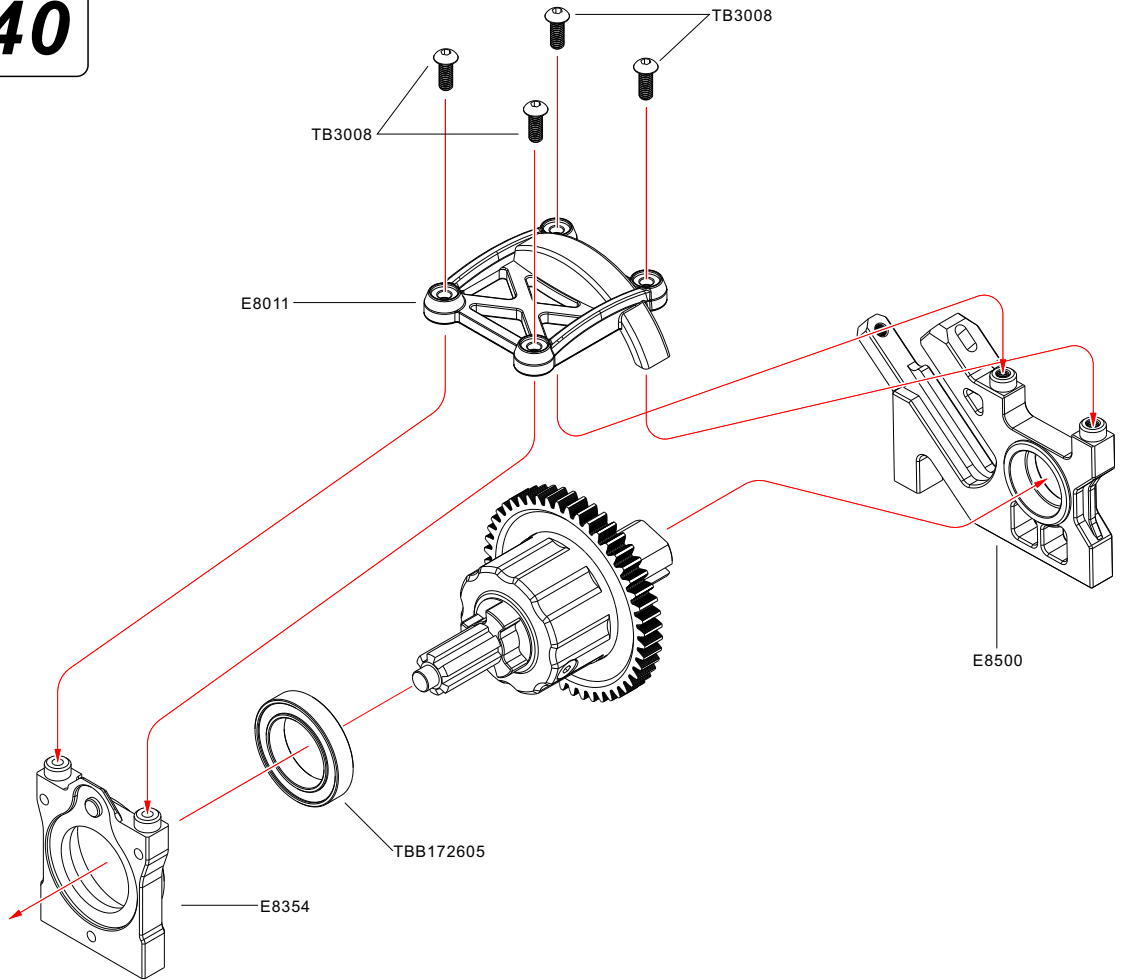

41



TC2508
M2.5×8mm

×1



TC3008
M3×8mm

×2



TB3008
M3×8mm

×1



TBB050903
Bearing 5×9×3mm

×1

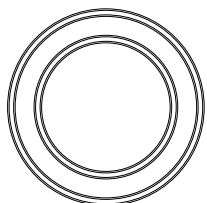

TBB172605
Bearing 17×26×5mm

×1

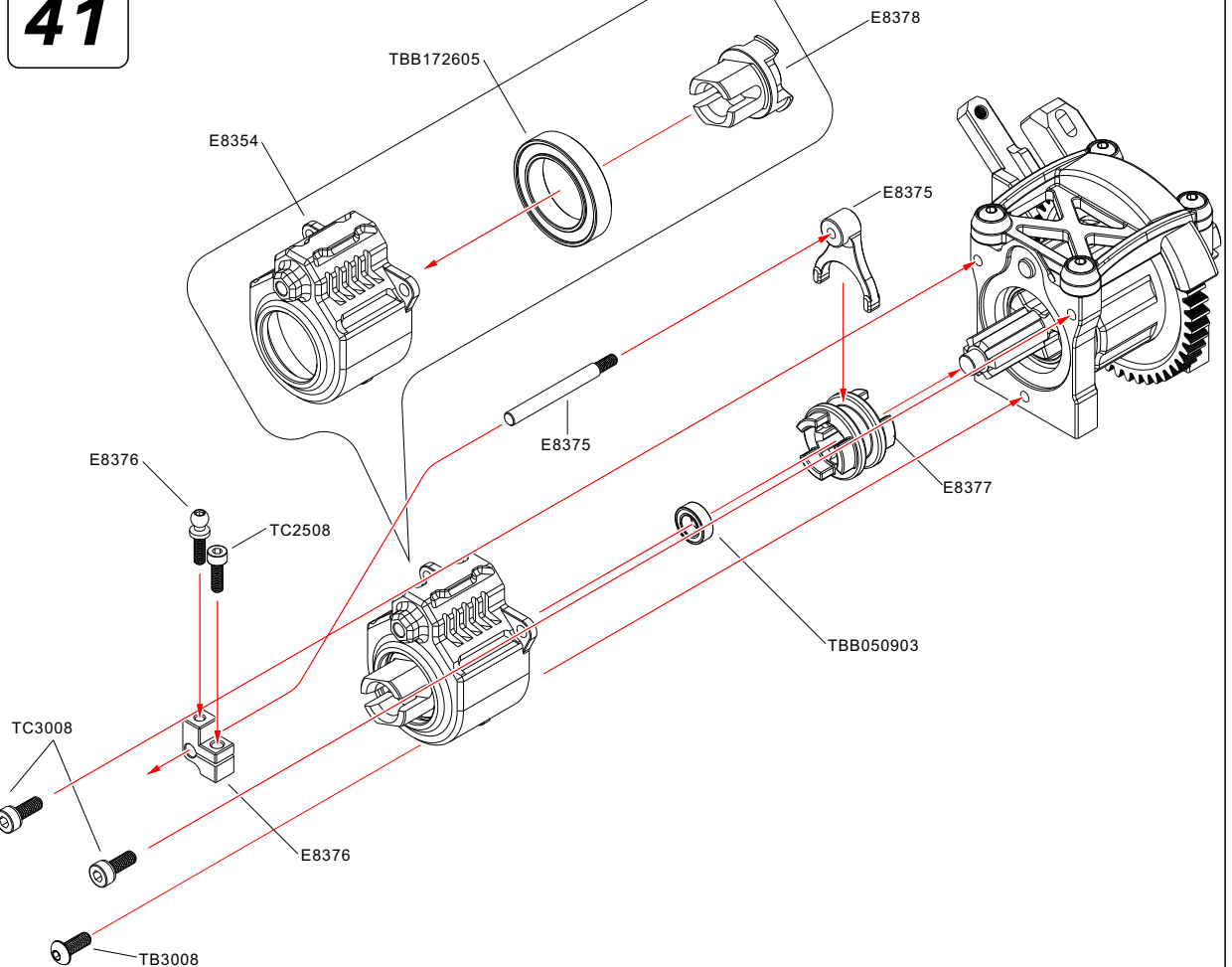

42

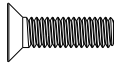

TF4014
M4×14mm ×2



TMS4004
Set Screw M4×4mm ×1

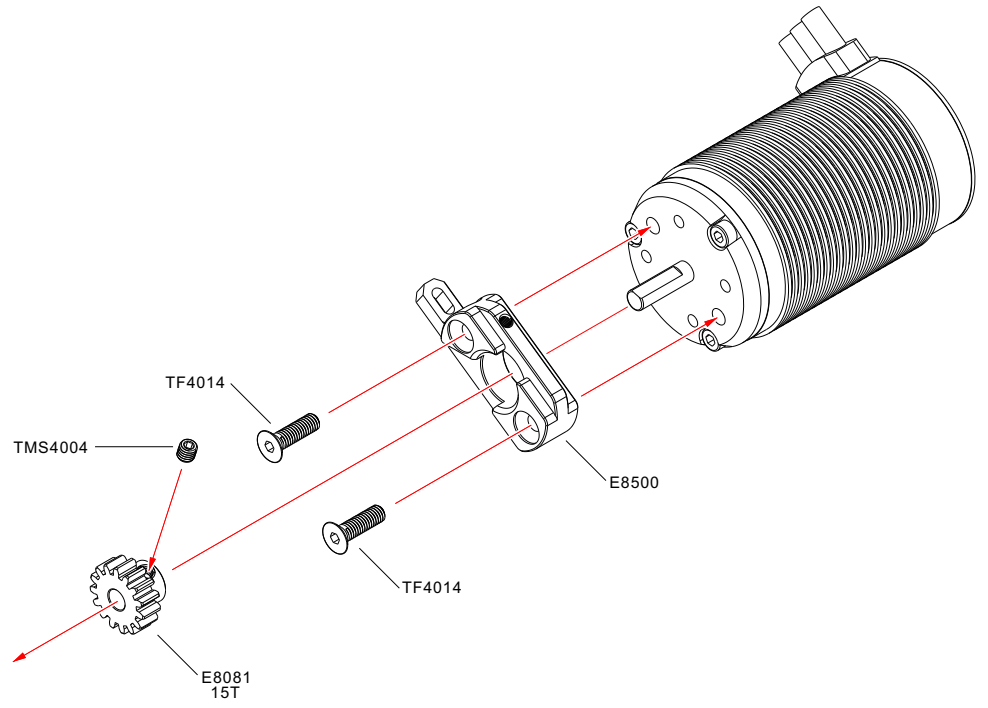

43



TC3010
M3×10mm ×1



TC3016
M3×16mm ×1



TW320810
Washer 3.2×8×1mm ×2

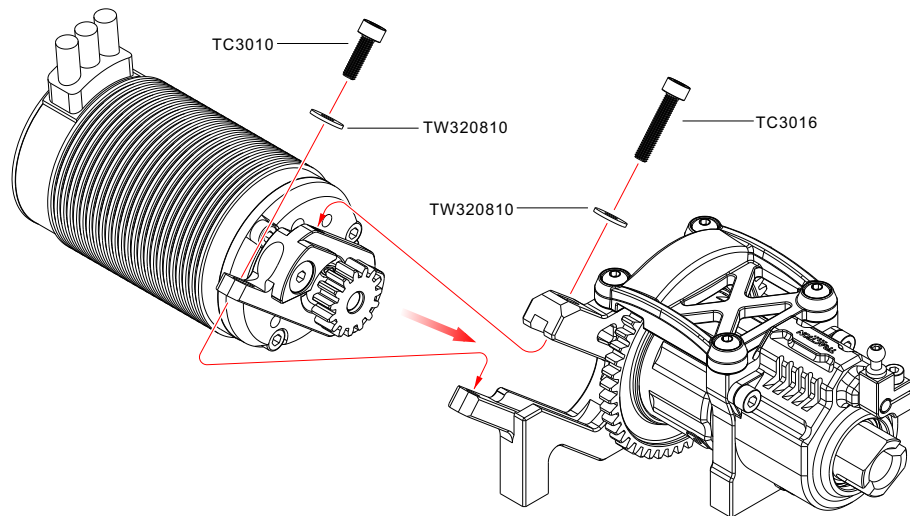

44

TF3008
M3×8mm

×2

TF3010
M3×10mm

×2

TF4010
M4×10mm

×2

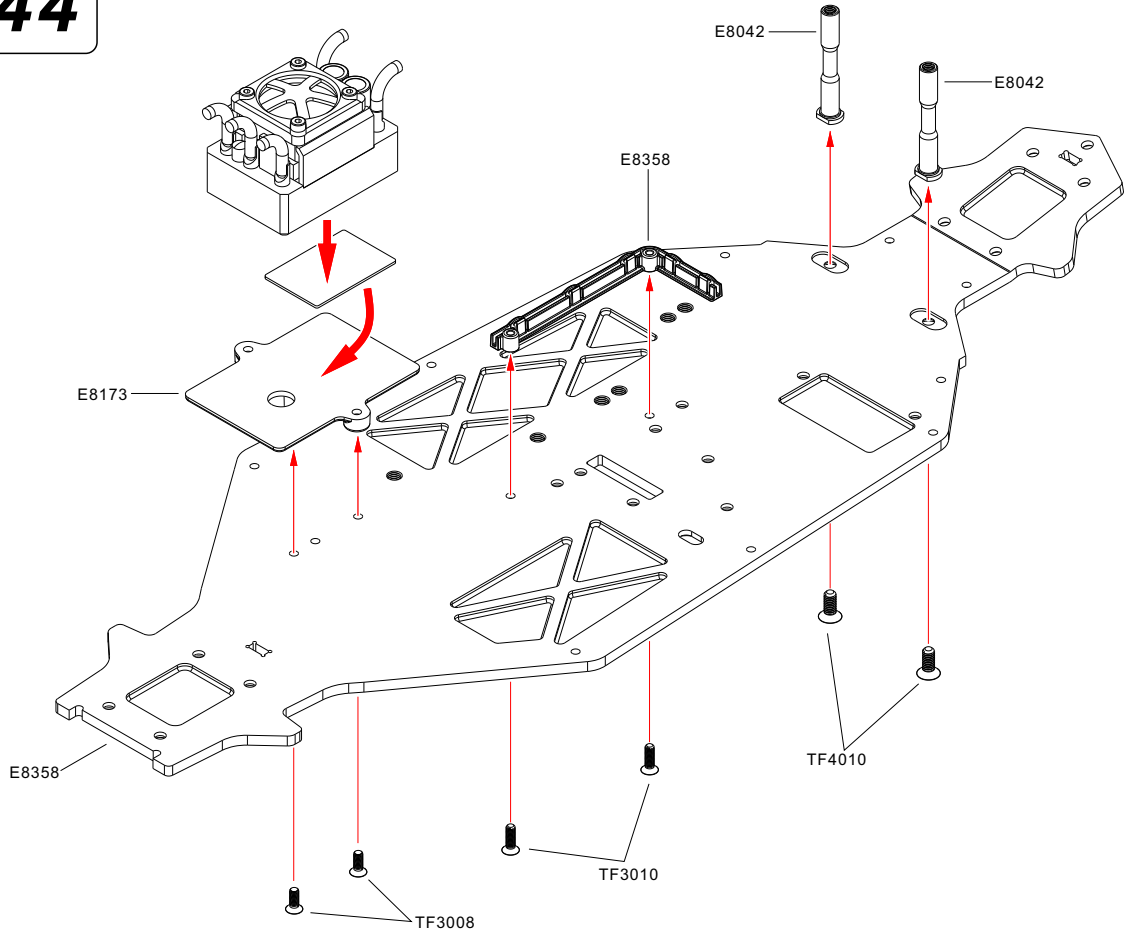

45

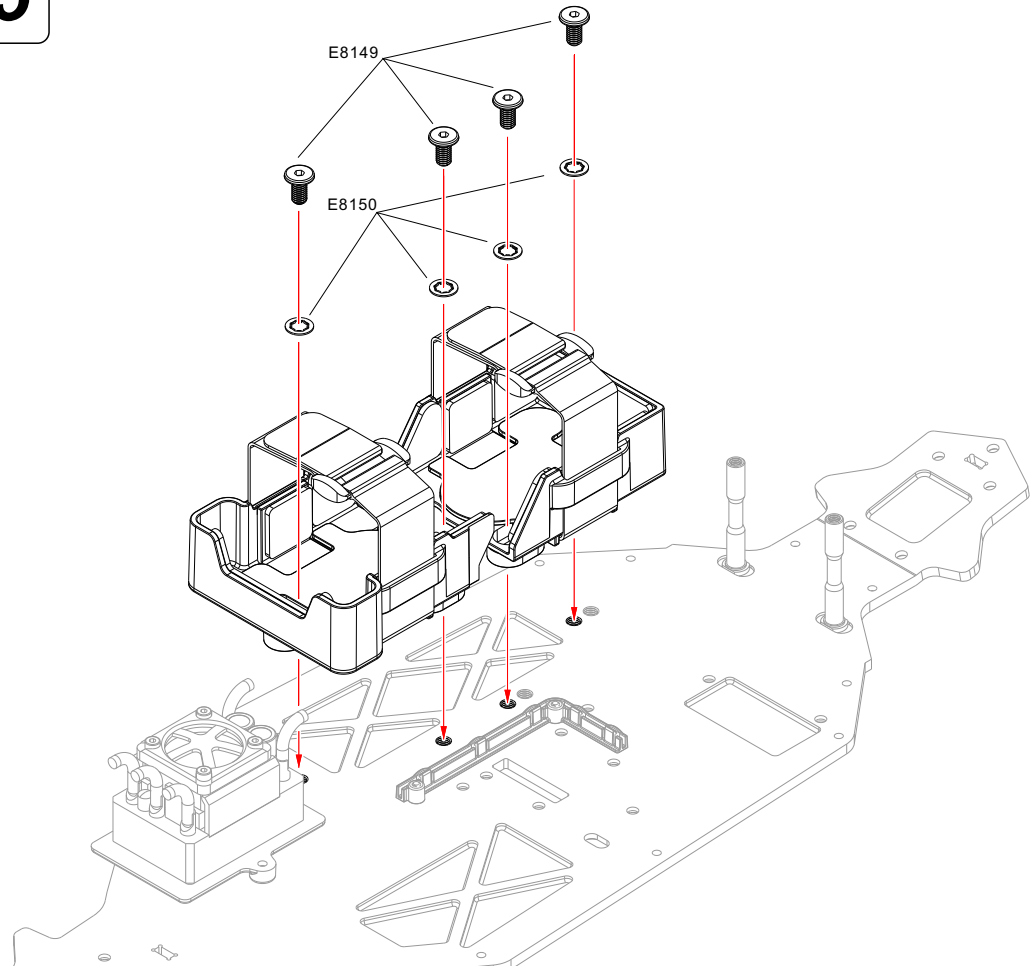

46



TF4008
M4×8mm

×3



TF4010
M4×10mm

×4

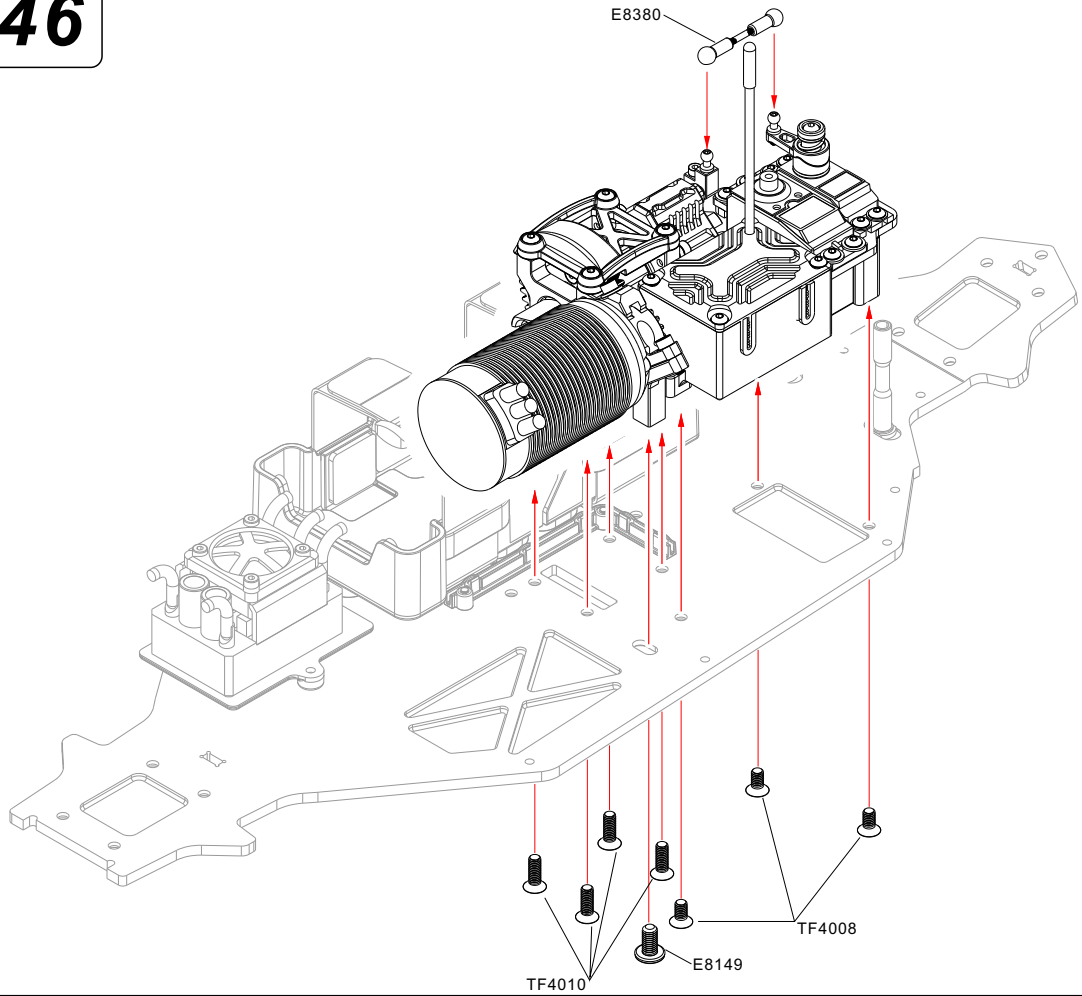

47 L/R



TB3010
M3×10mm

×8



TF3010
M3×10mm

×8

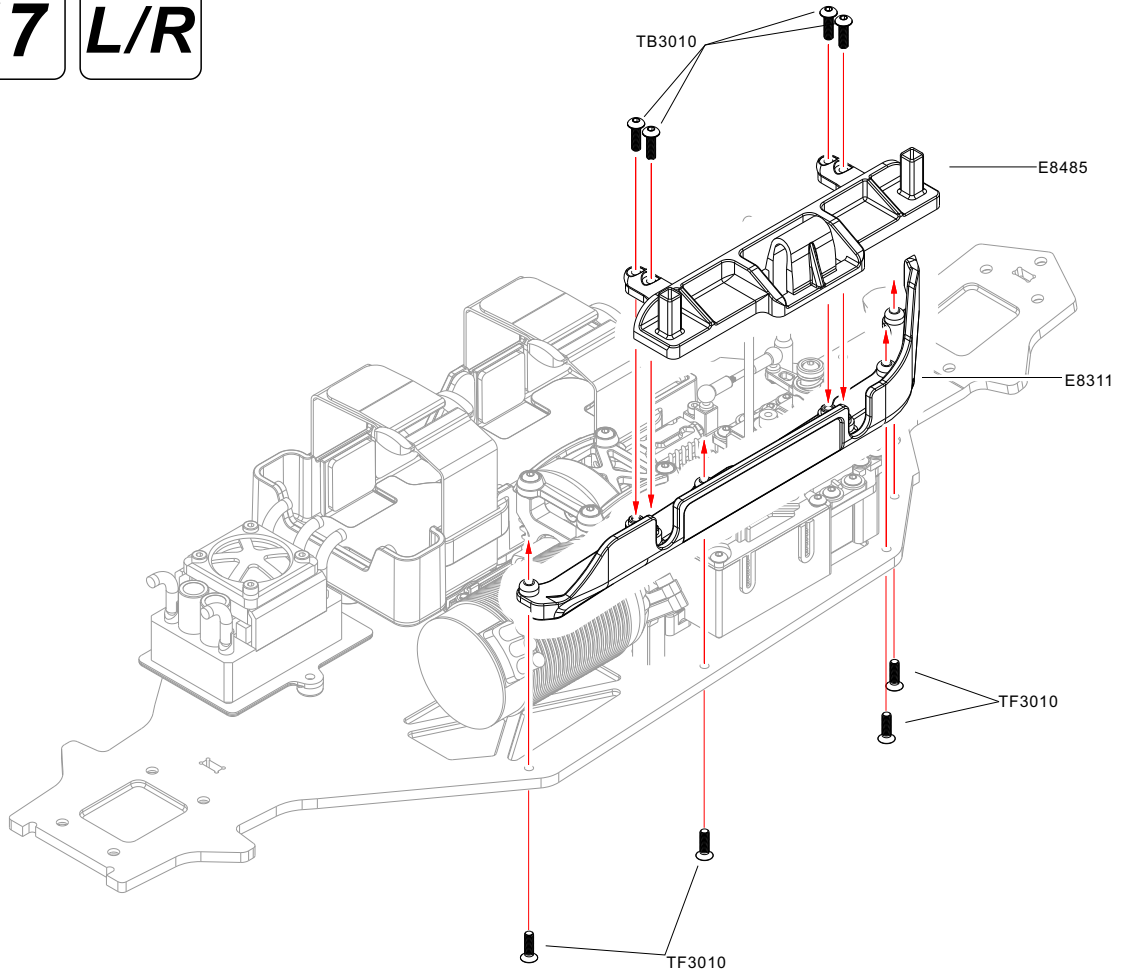

48



TF3010
M3×10mm

×2



TF4012
M4×12mm

×1



TF4016
M4×16mm

×4

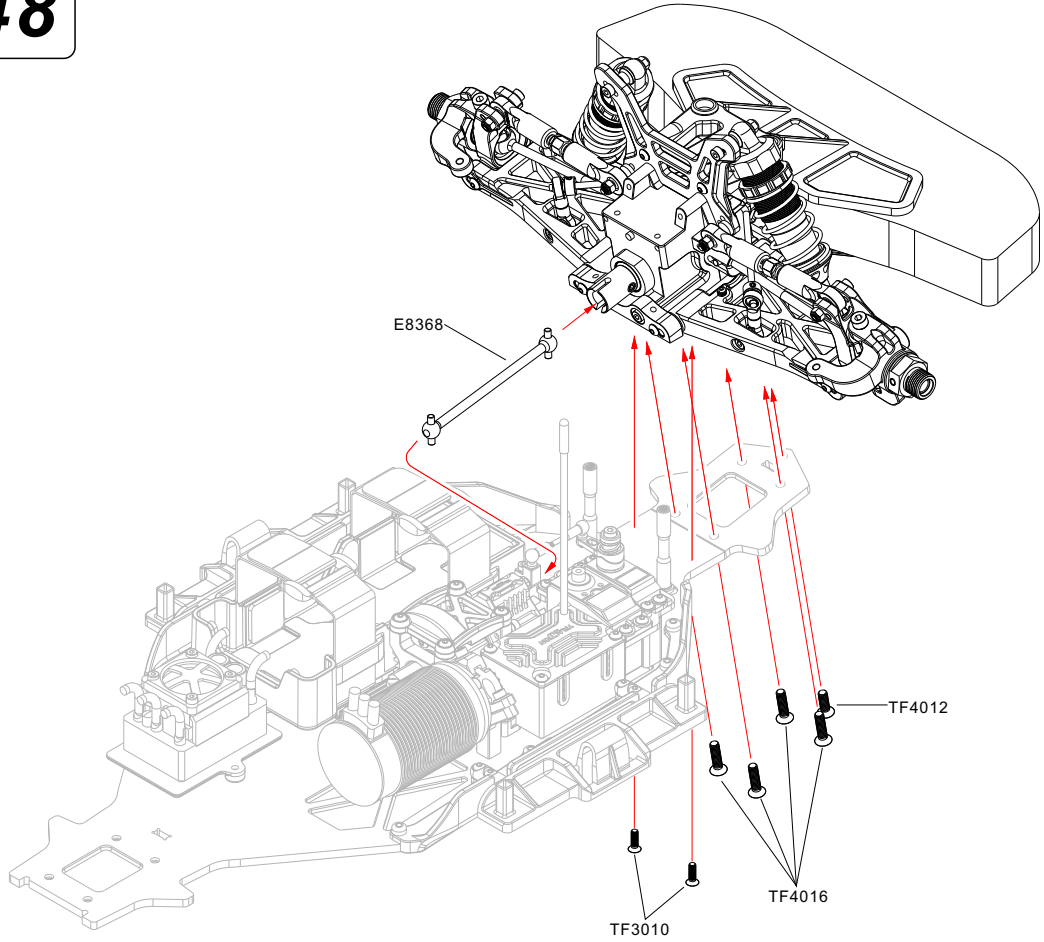

49



TB3008
M3×8mm

×1



TF3016
M3×16mm

×2

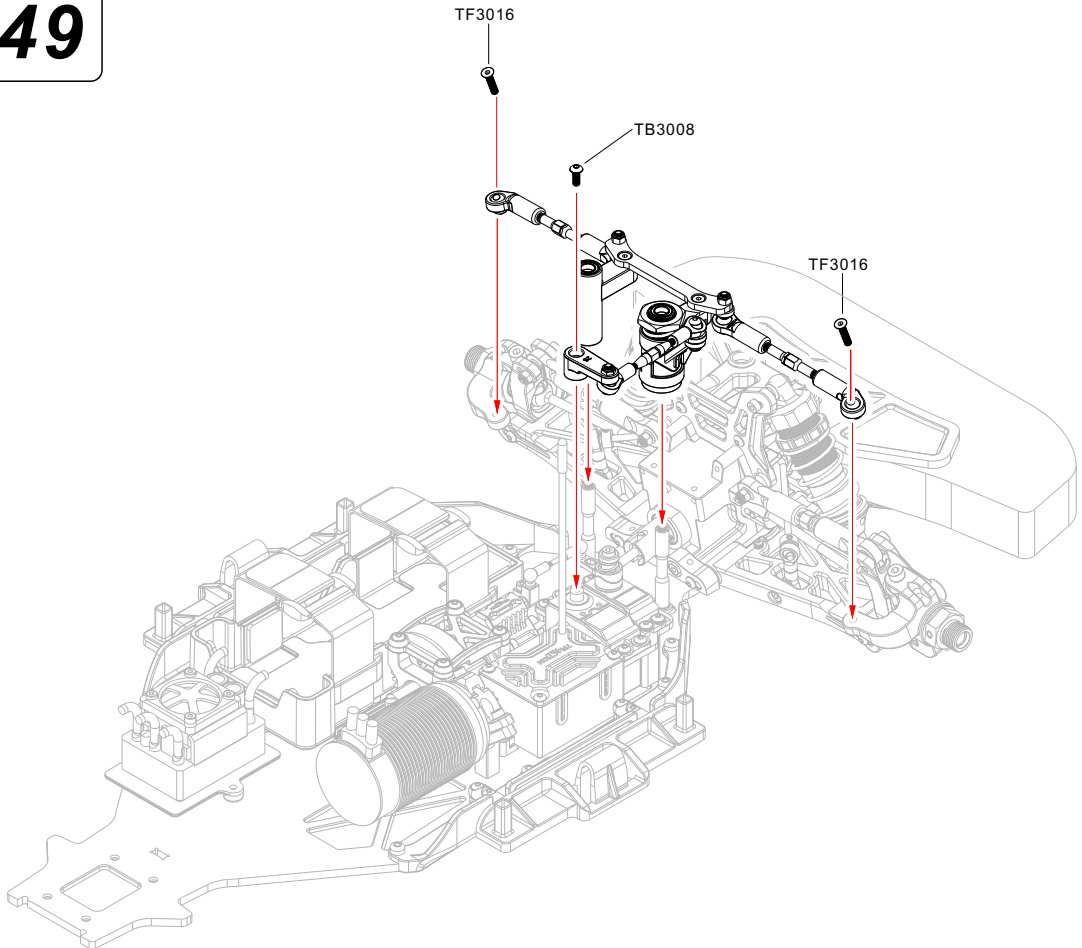



TB3010
M3×10mm

×2



TB3012
M3×12mm

×1



TB4010
M4×10mm

×2



TMN30
M3 Nylon Nut

×1



TMN40
M4 Nylon Nut

×1



TF4016
M4×16mm

×1

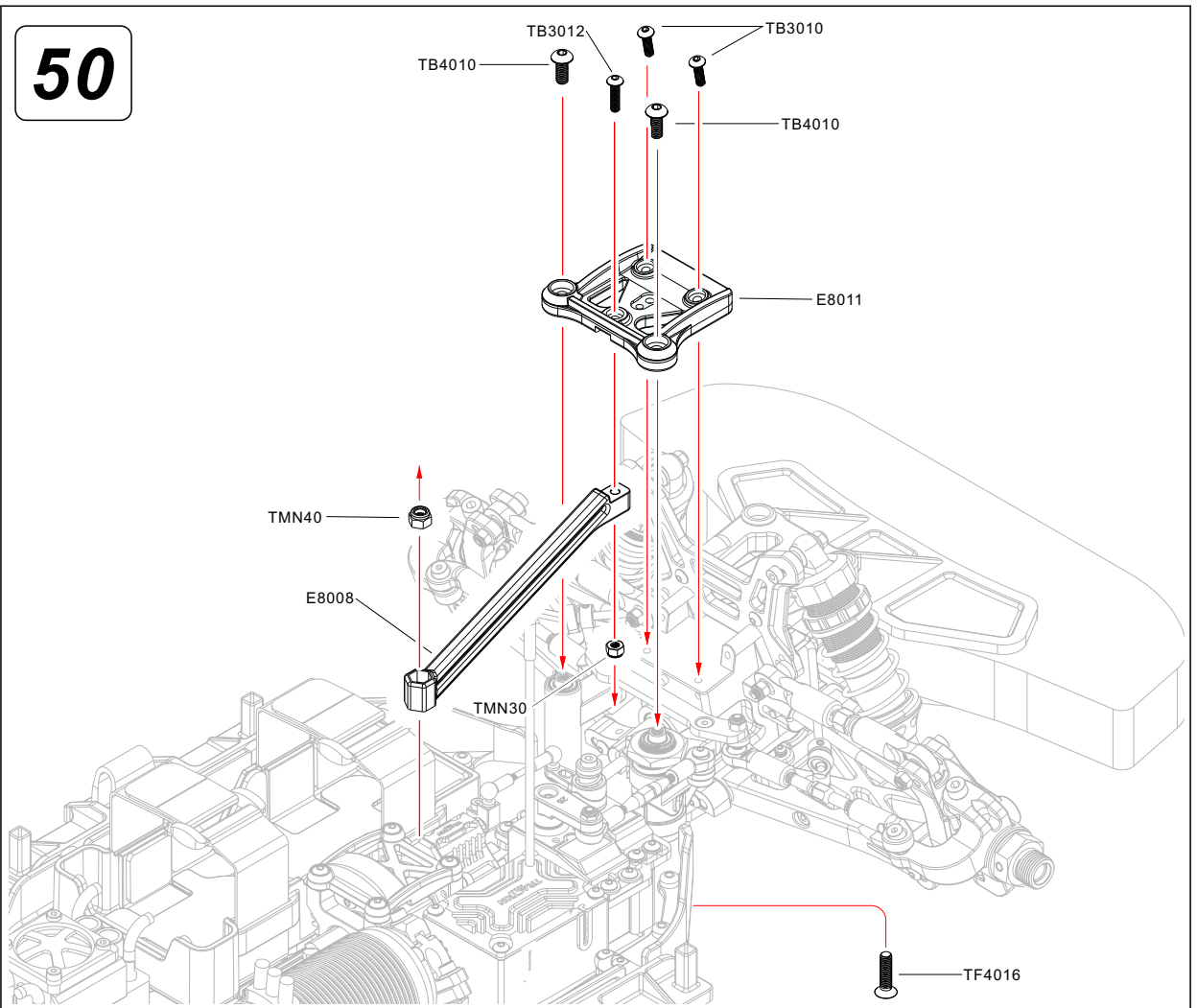

TB3012
M3×12mm

×2



TF4016
M4×16mm

×3



TMN40
M4 Nylon Nut

×1

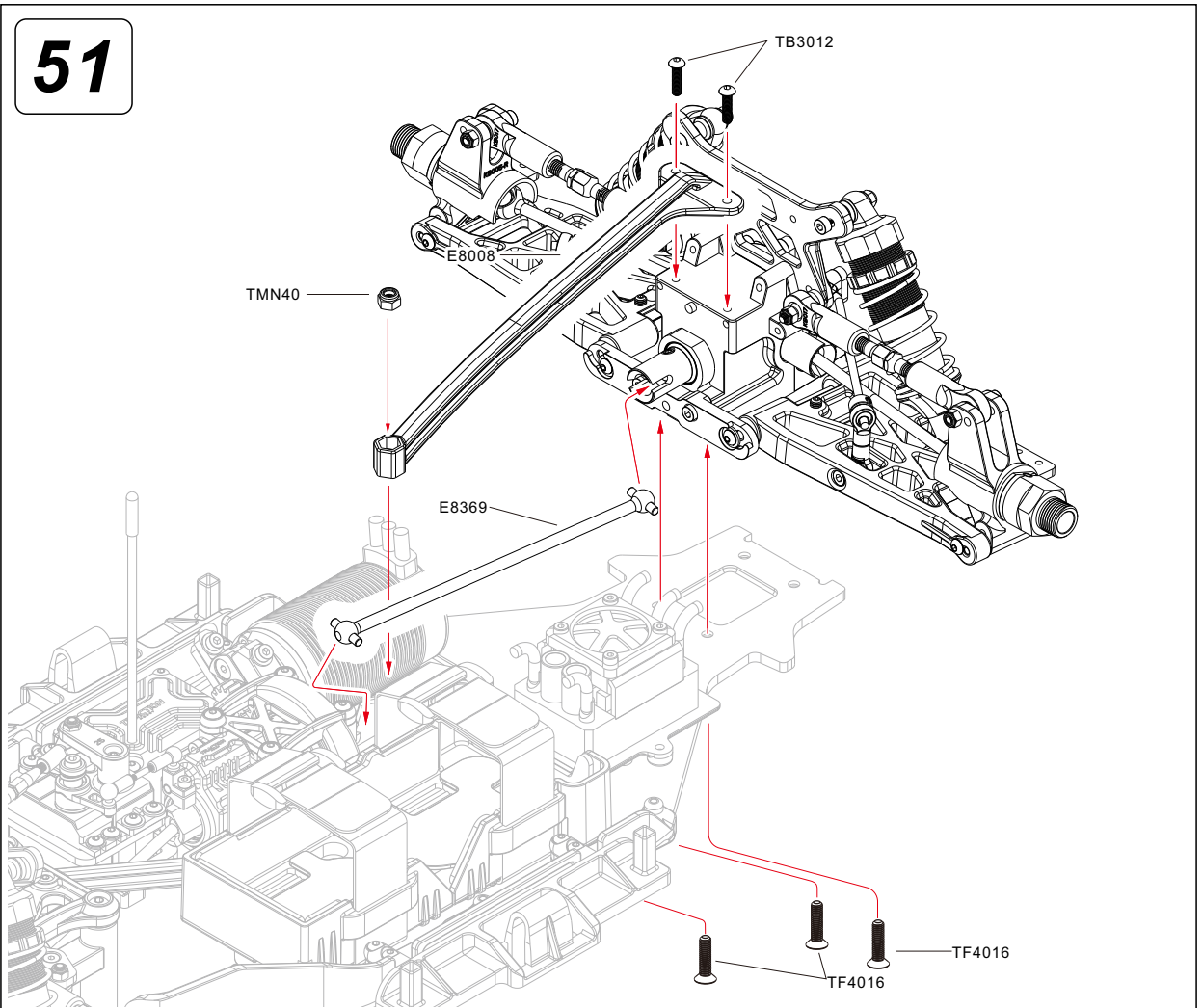



TF4016
M4×16mm

×2

52



TB3010
M3×10mm

×2

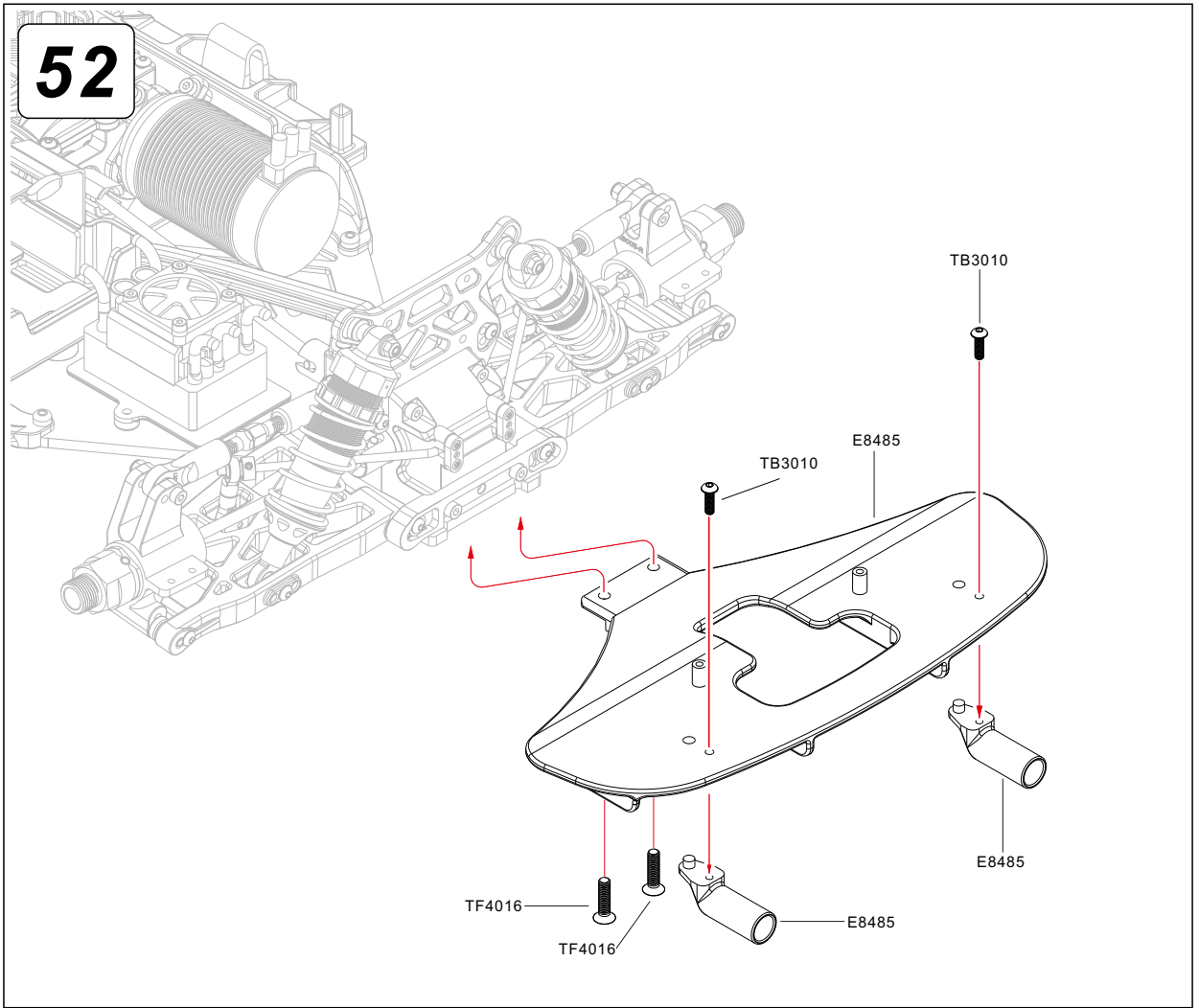

TB3008
M3×8mm

×2

53



TB3014
M3×14mm

×2

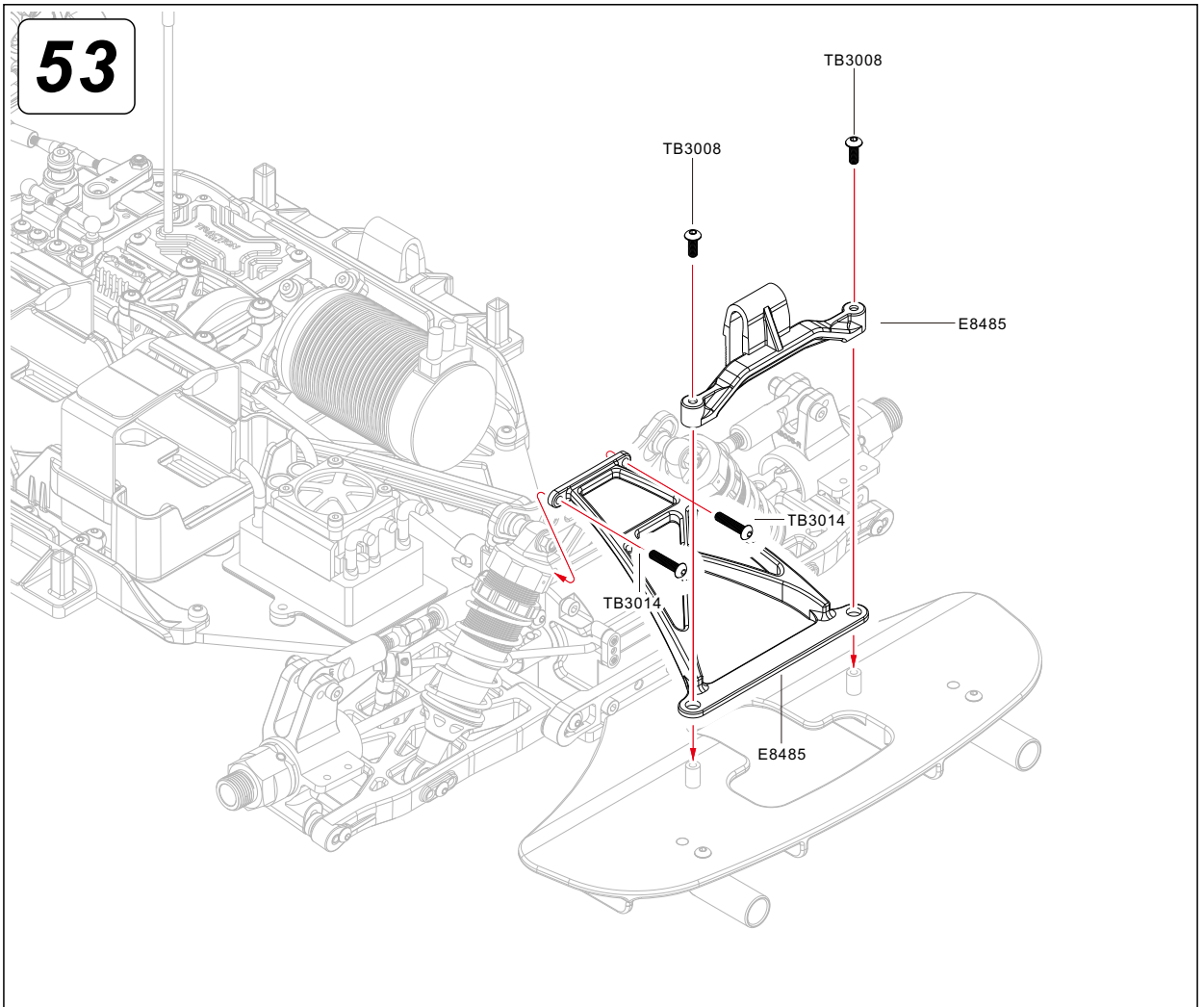

54 L/R

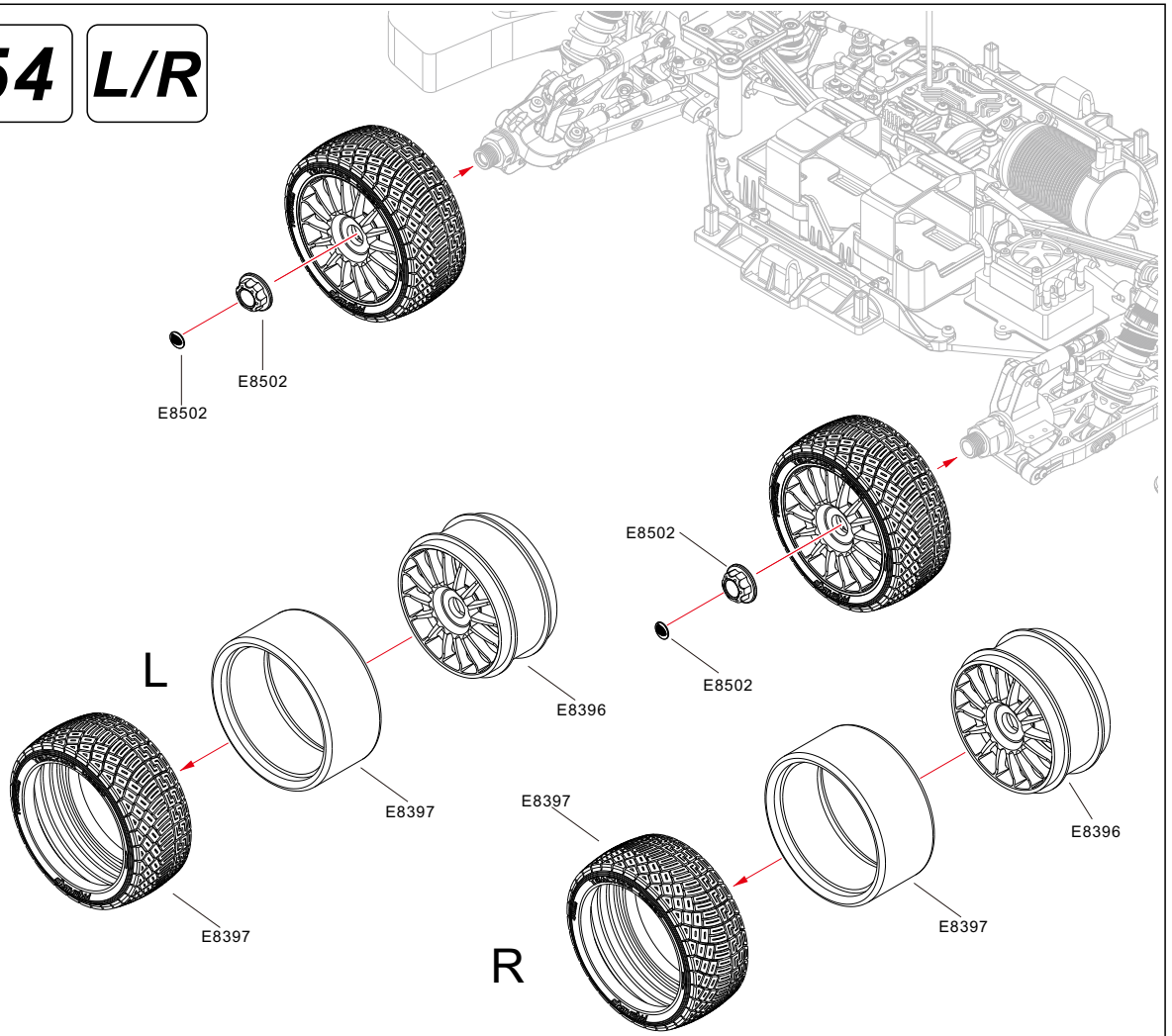

55

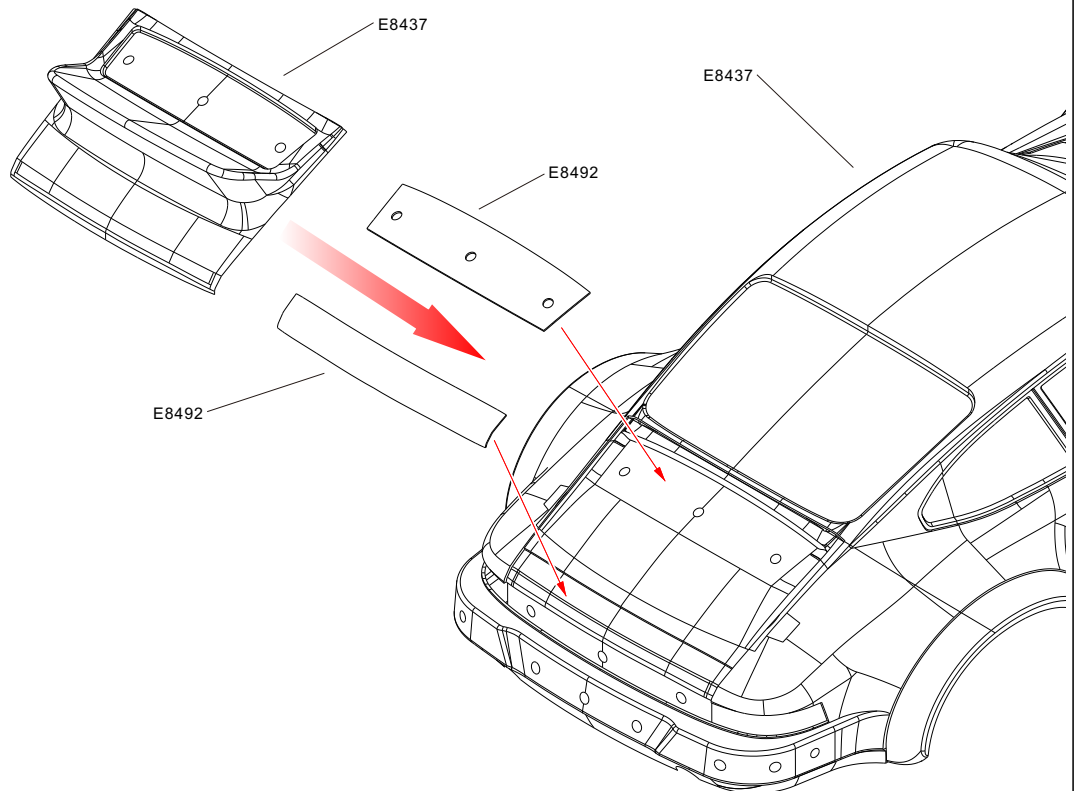

TC2006
M2x6mm

x6

56 **L/R**

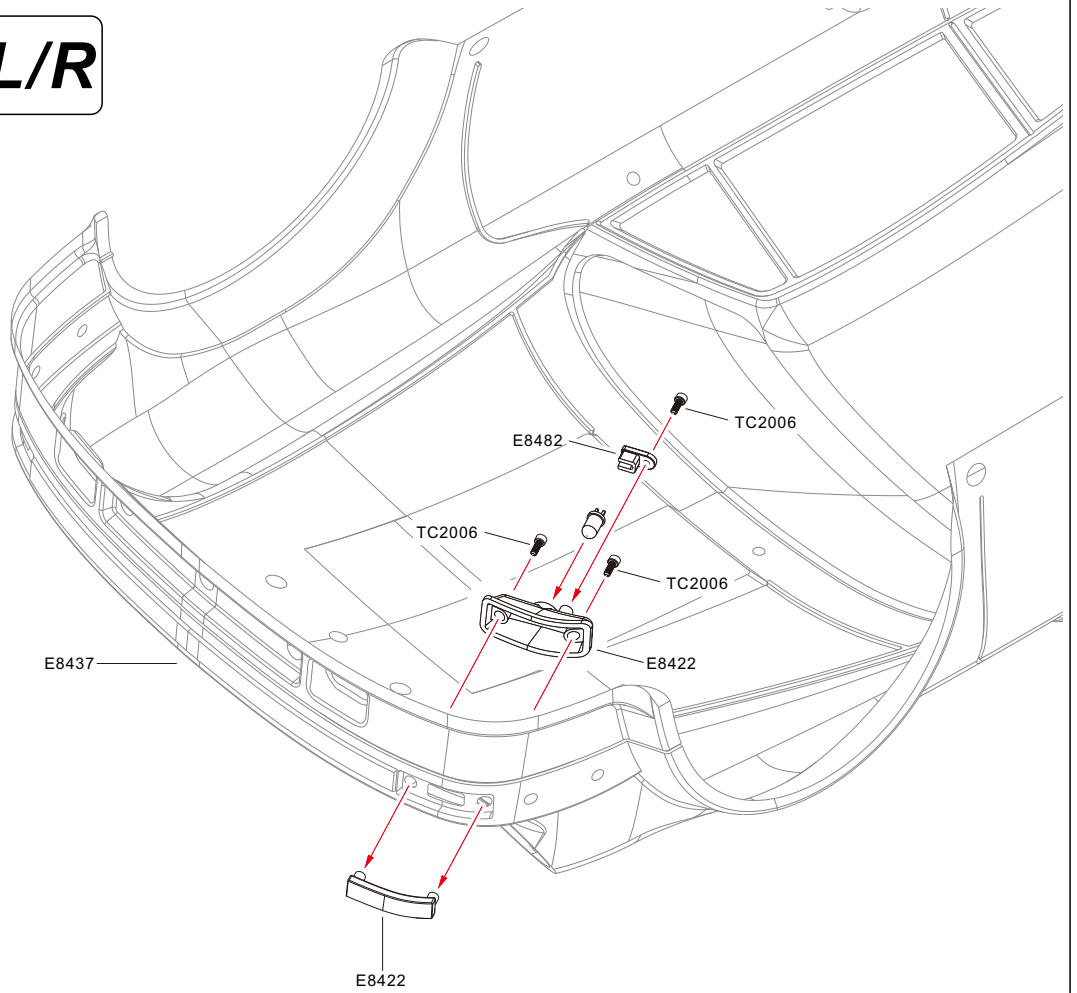

TC2006
M2x6mm

x4

57 **L/R**

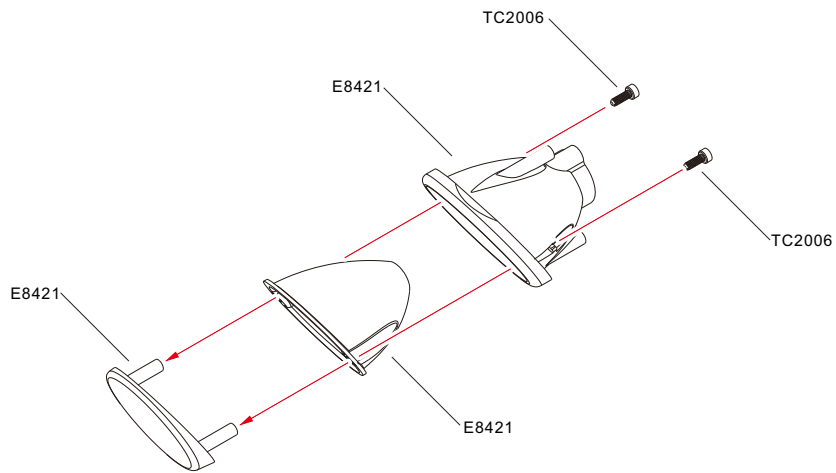

TC2006
M2×6mm

x8

58 L/R

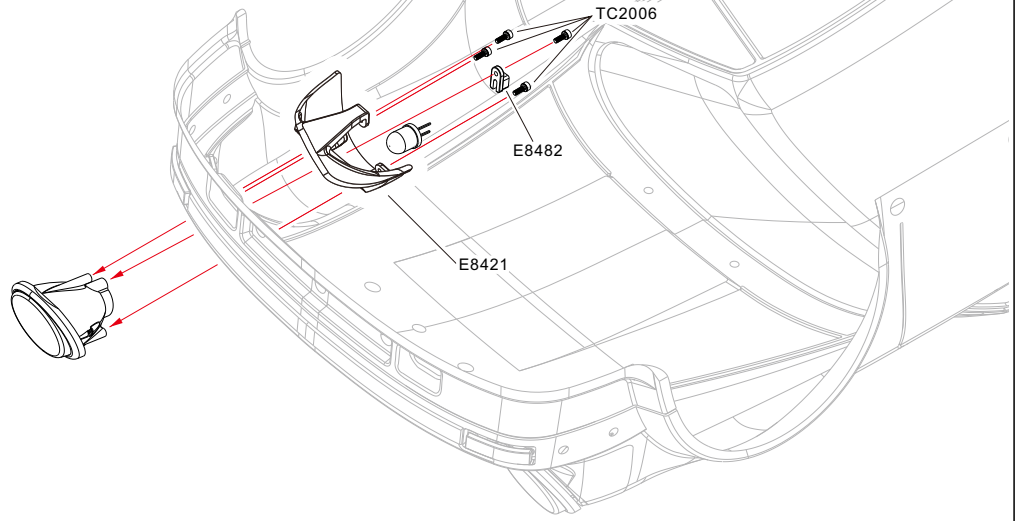

TC2006
M2×6mm

x3

TB2512
M2. 5×12mm

x2

TB3008
M3×8mm

x3

59

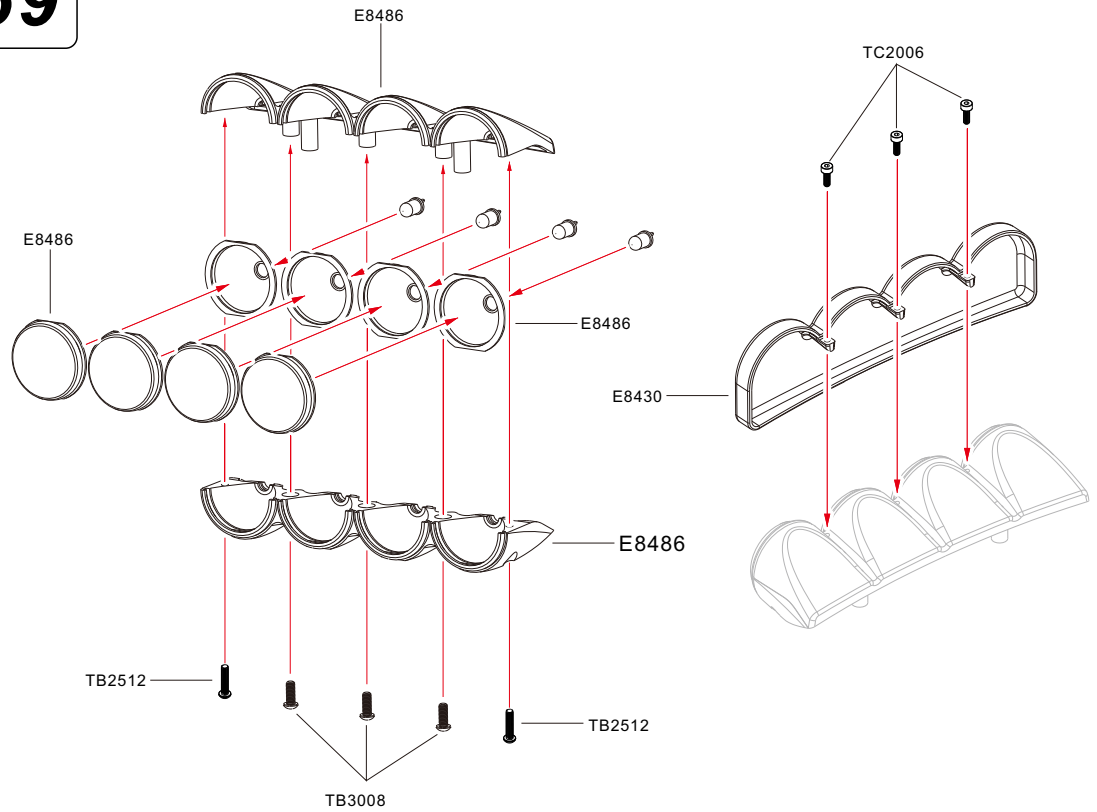



TB3008
M3×8mm

×2

60

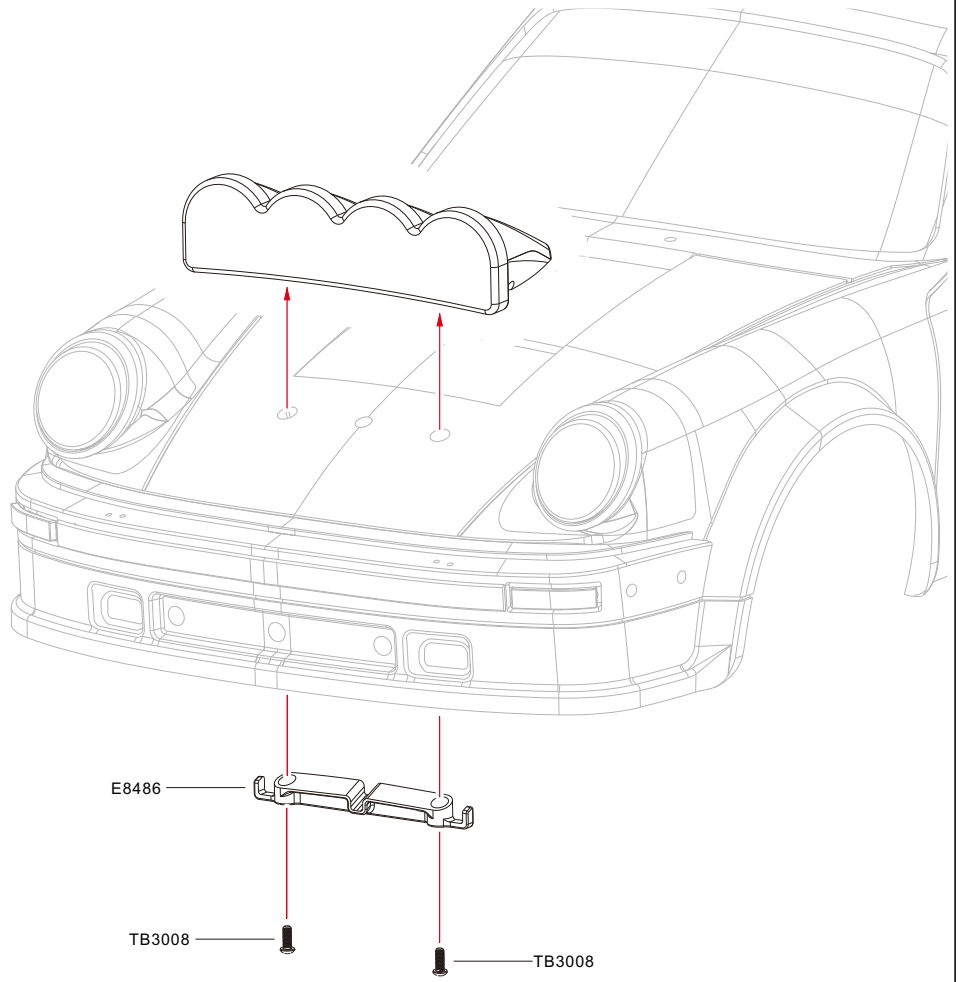

TC1606
M1.6×6mm

×4

61 **L/R**

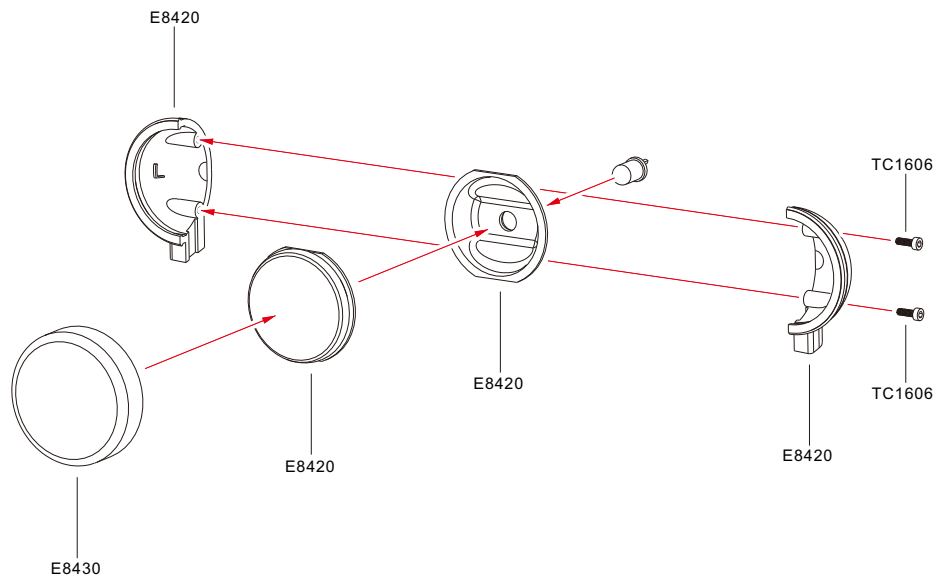

TC2010
M2×10mm

×4

62 **L/R**

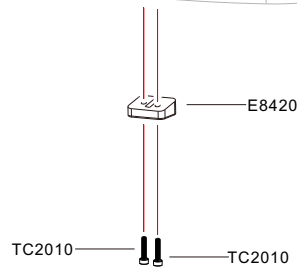
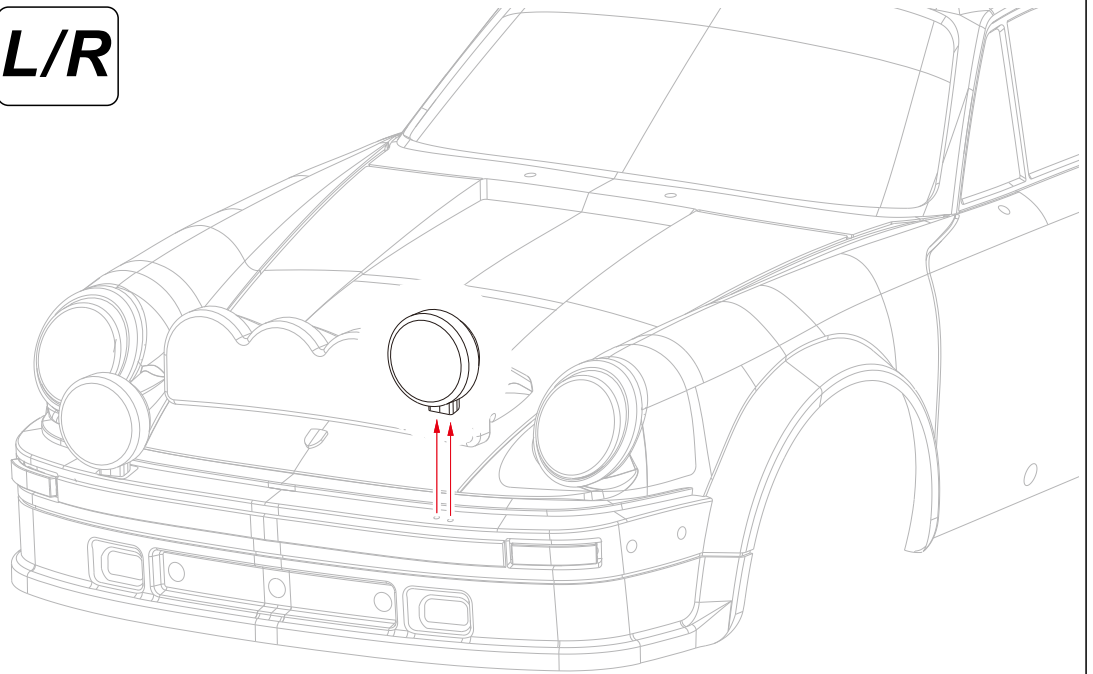

TC1606
M1.6×6mm

×6

63 **L/R**

TC2006
M2×6mm

×6

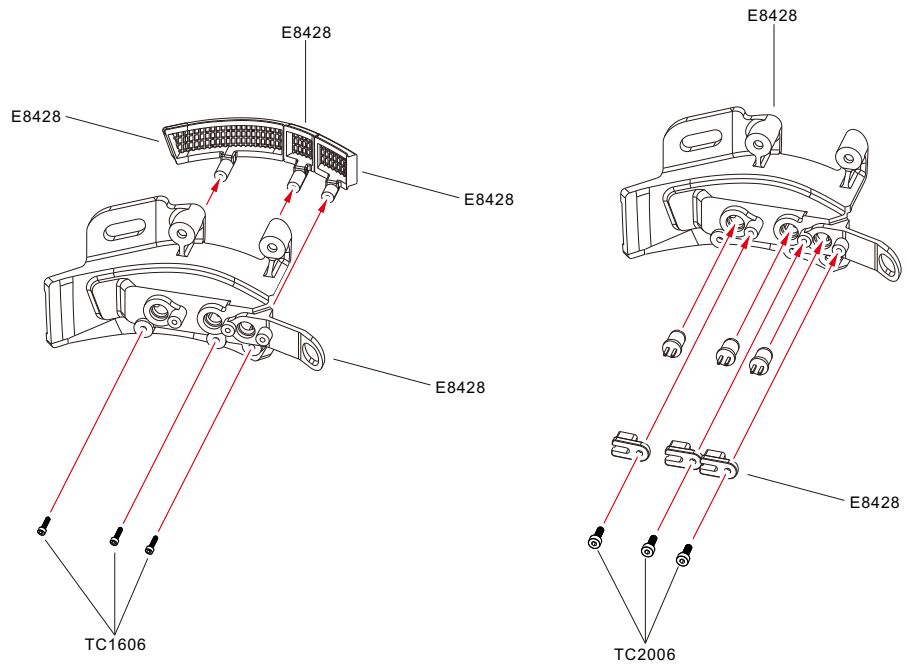



TB3008
M3x8mm



TB3008
M3x8mm

×6

64 **L/R**

×6

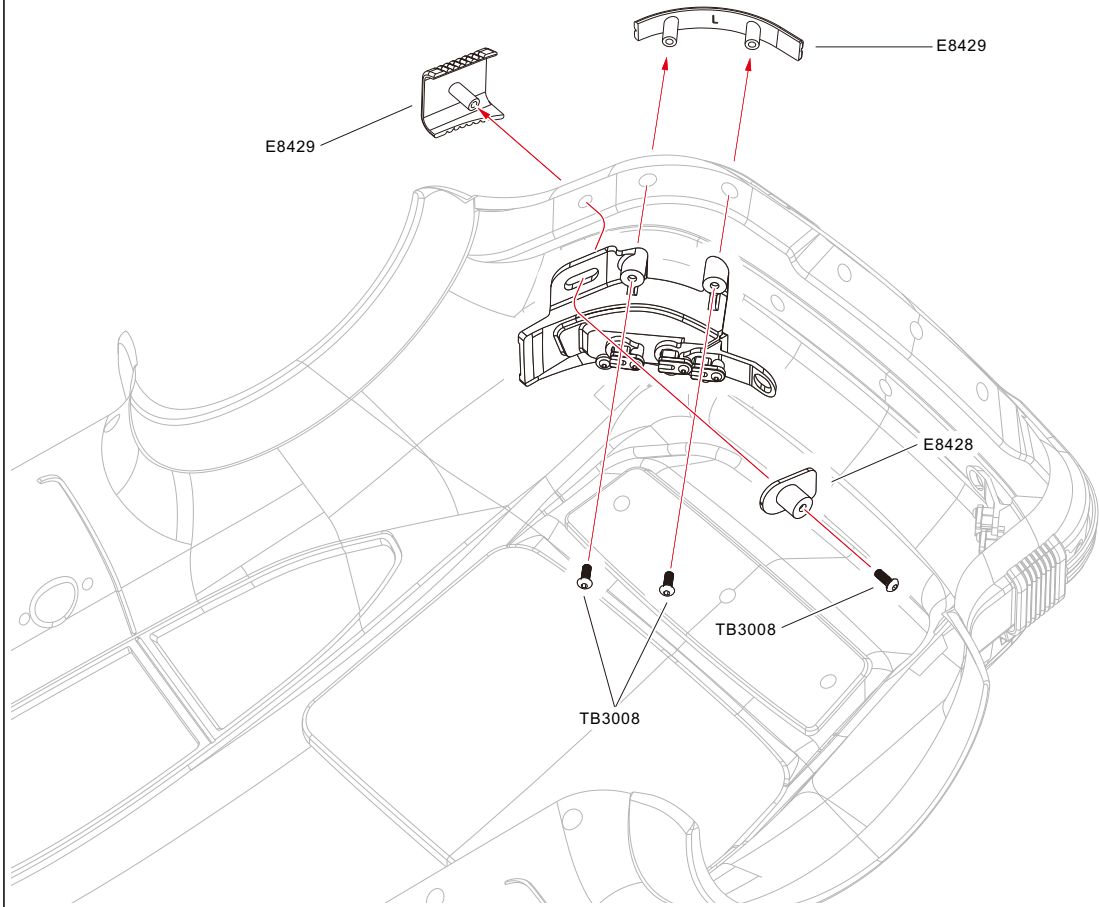

TC1606
M1.6x6mm



TC2006
M2x6mm

×4

65 **L/R**

×4

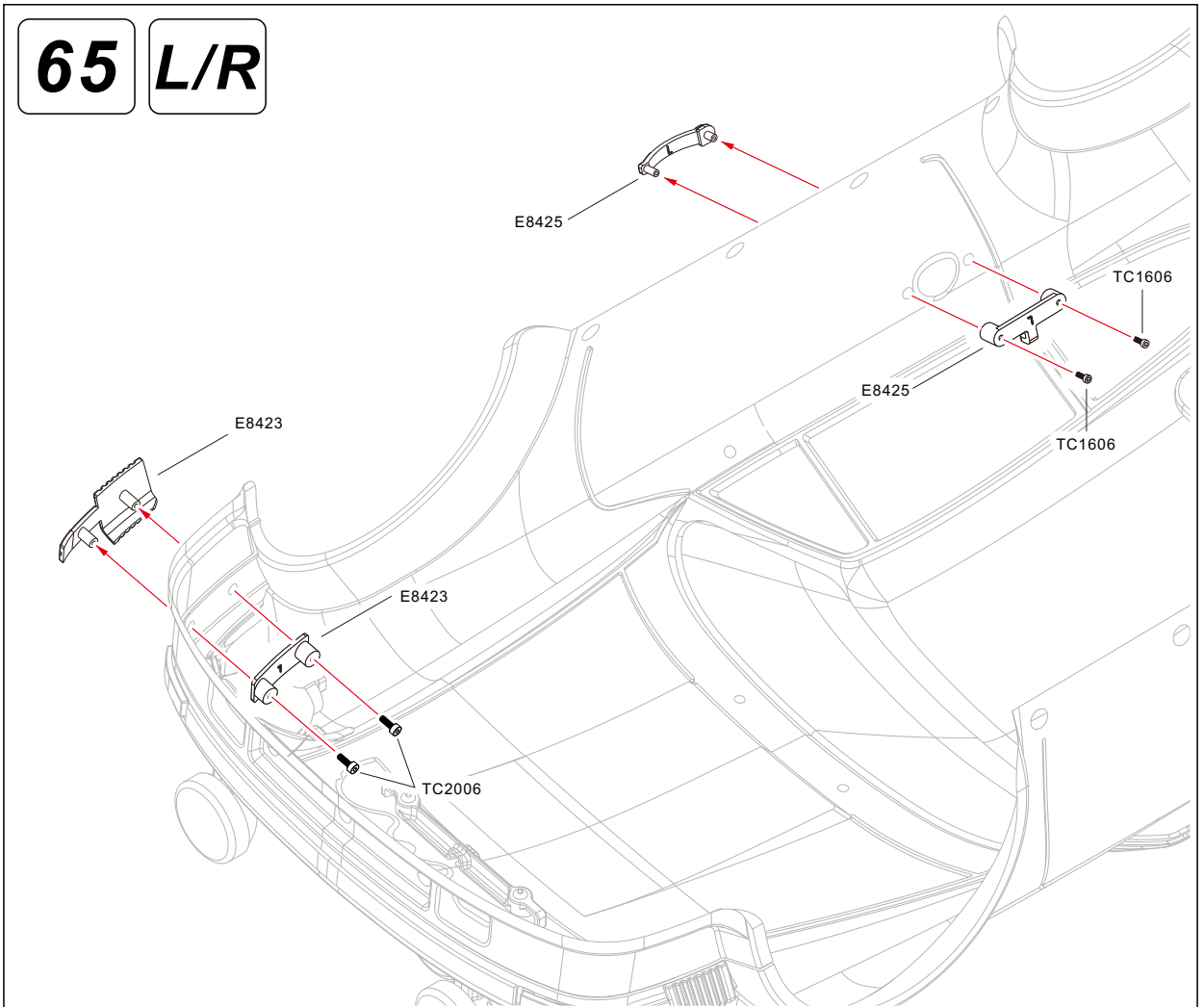

TB3008
M3×8mm

×8

66

L/R

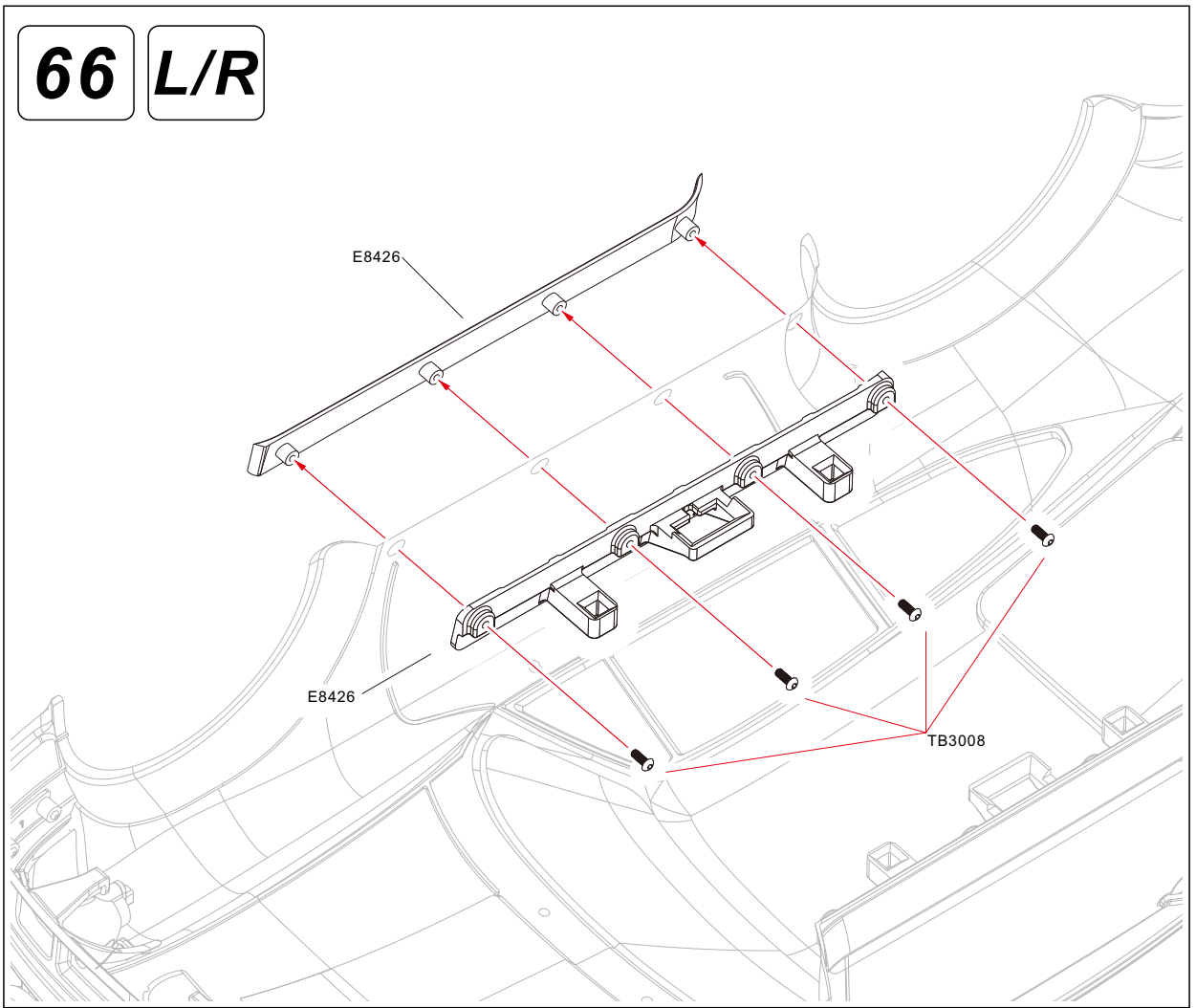

TB3008
M3×8mm

×6

67

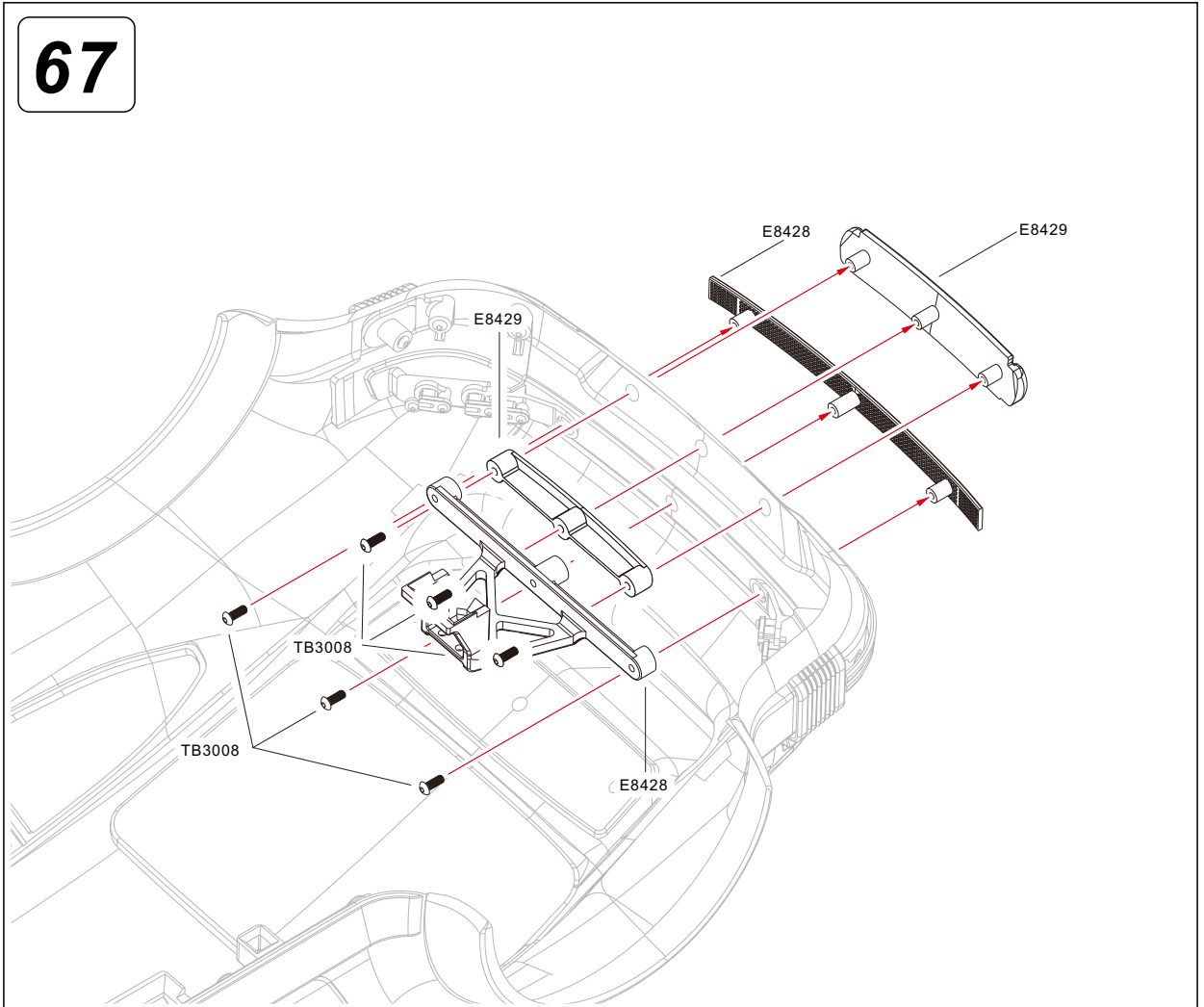



TB3008
M3×8mm

×1

68



TB3006
M3×6mm

×2

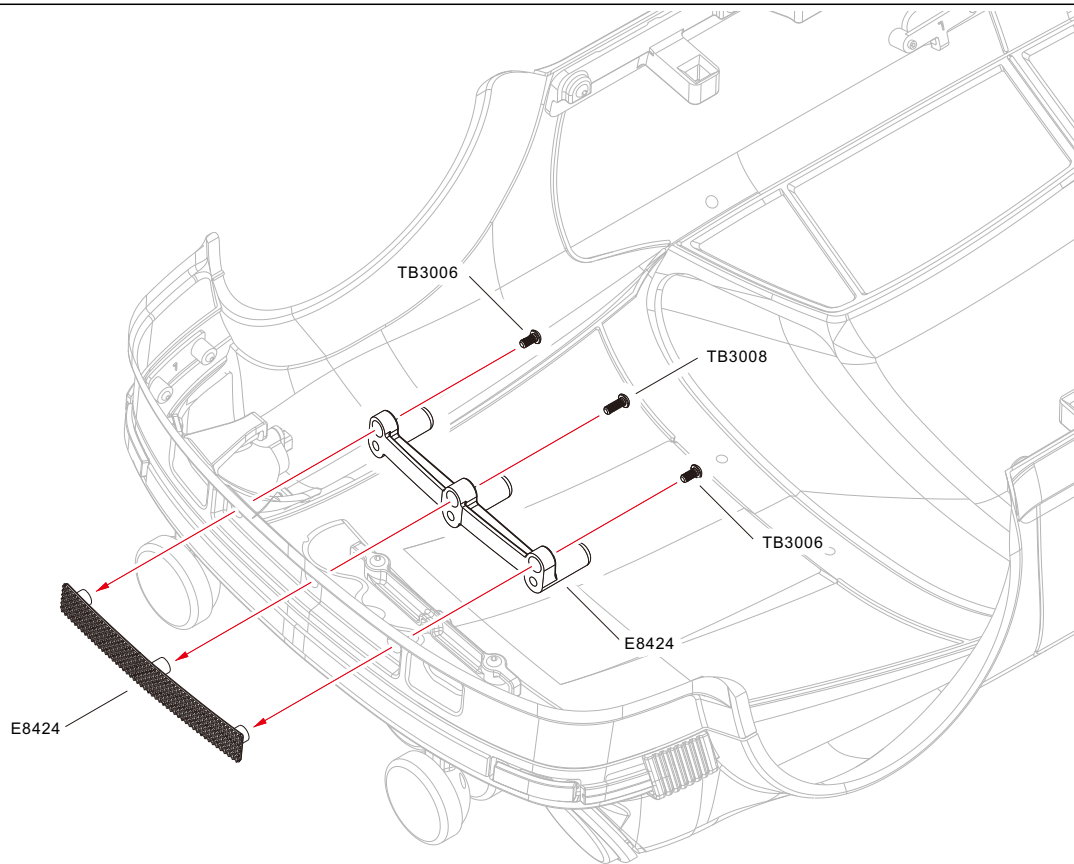

TB3008
M3×8mm

×6

69



TW320810
Washer 3.2×8×1mm

×2

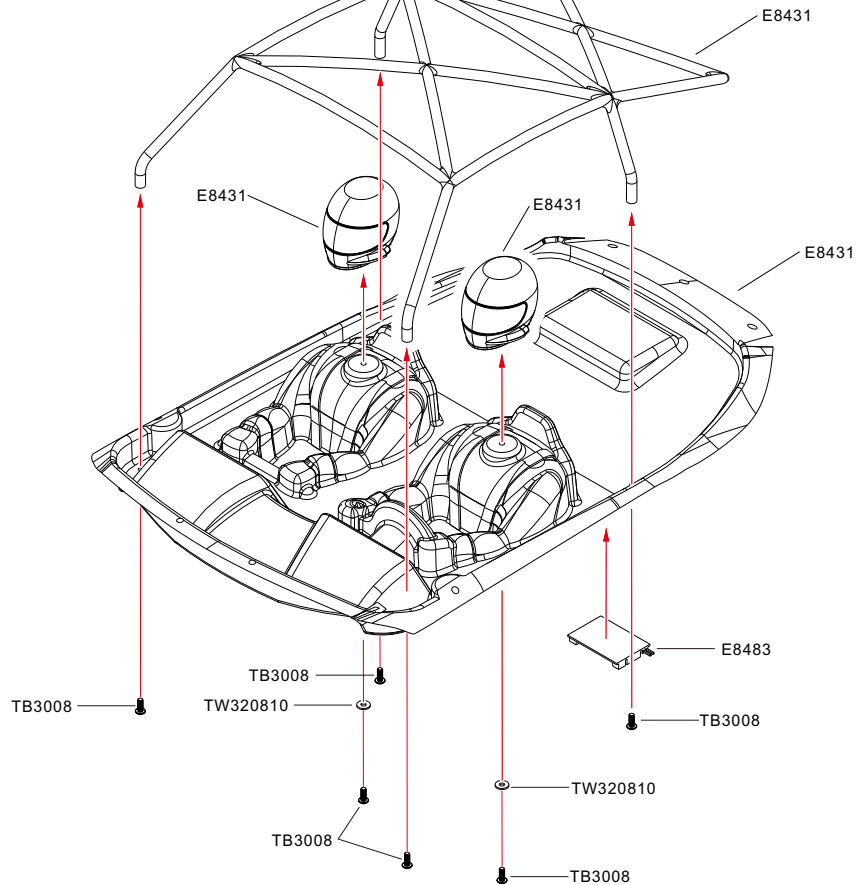

TB3006
M3×6mm

×2

70

TB3010
M3×10mm

×3

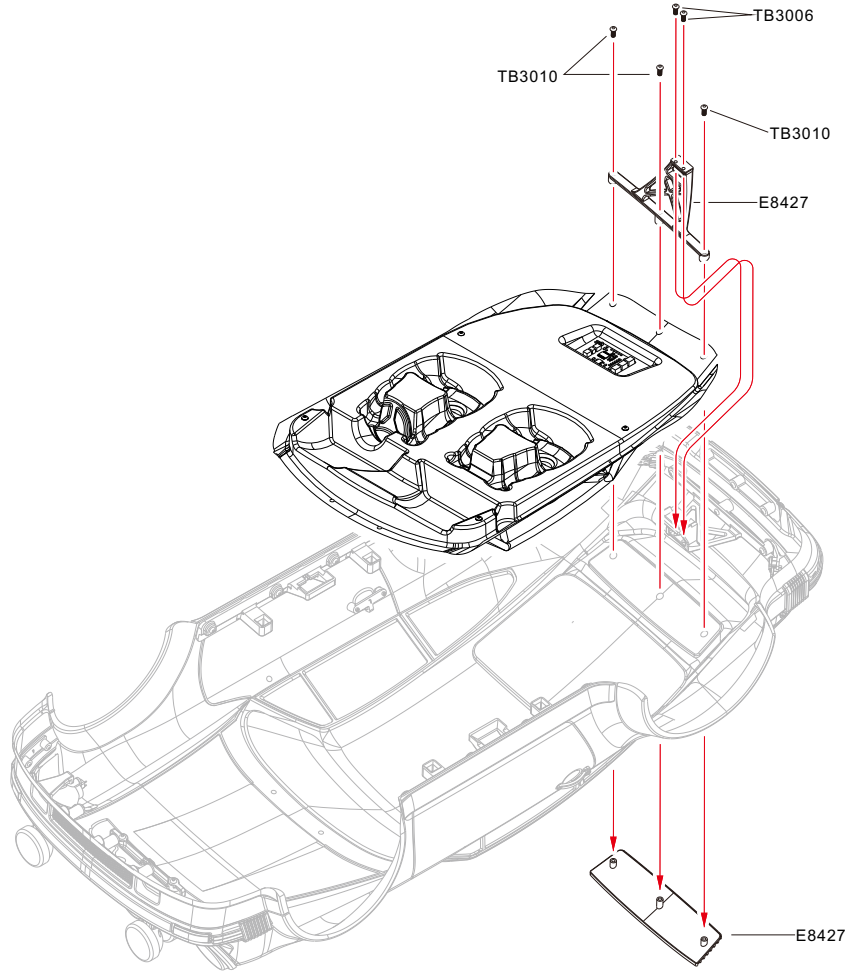

TC1606
M1.6×6mm

×2

71

TC2008
M2×8mm

×2

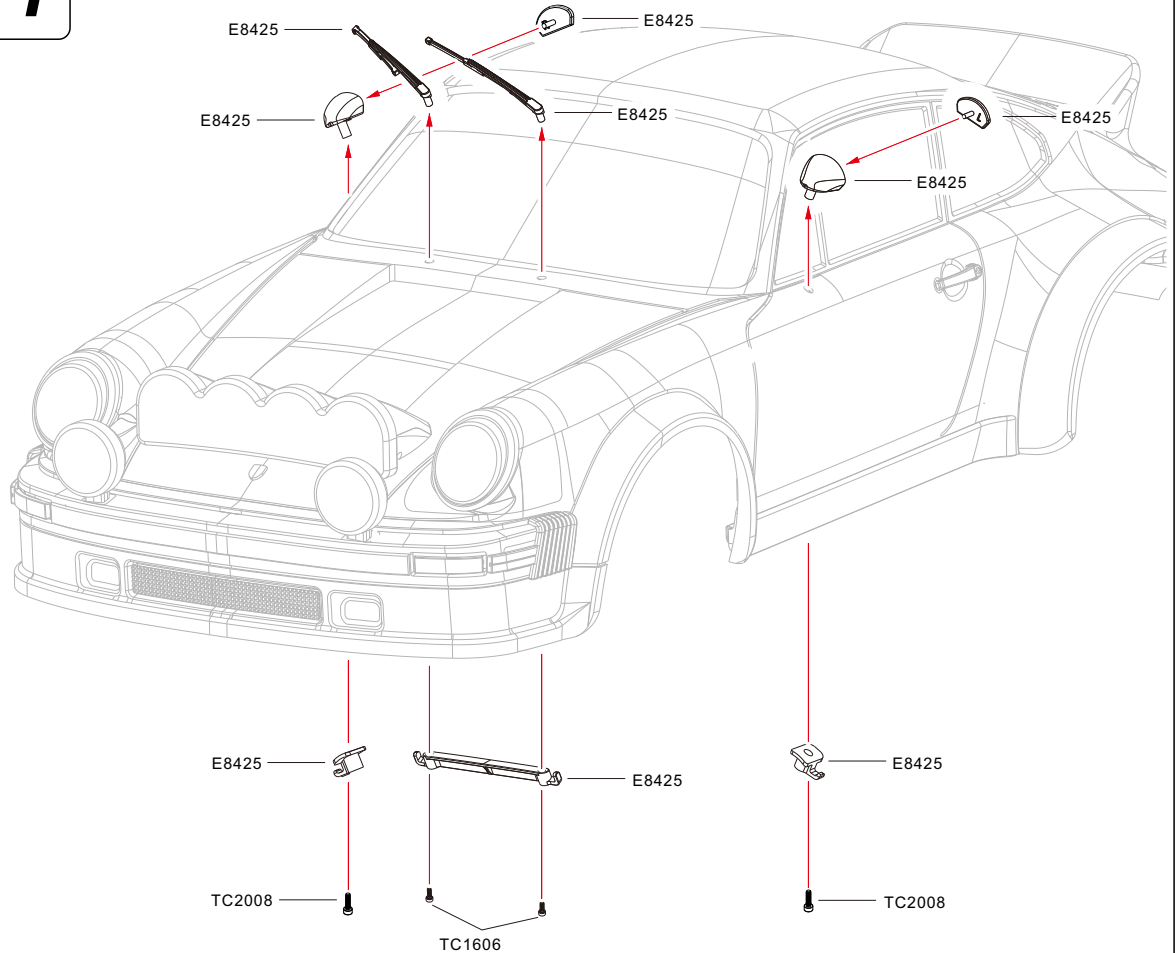

72

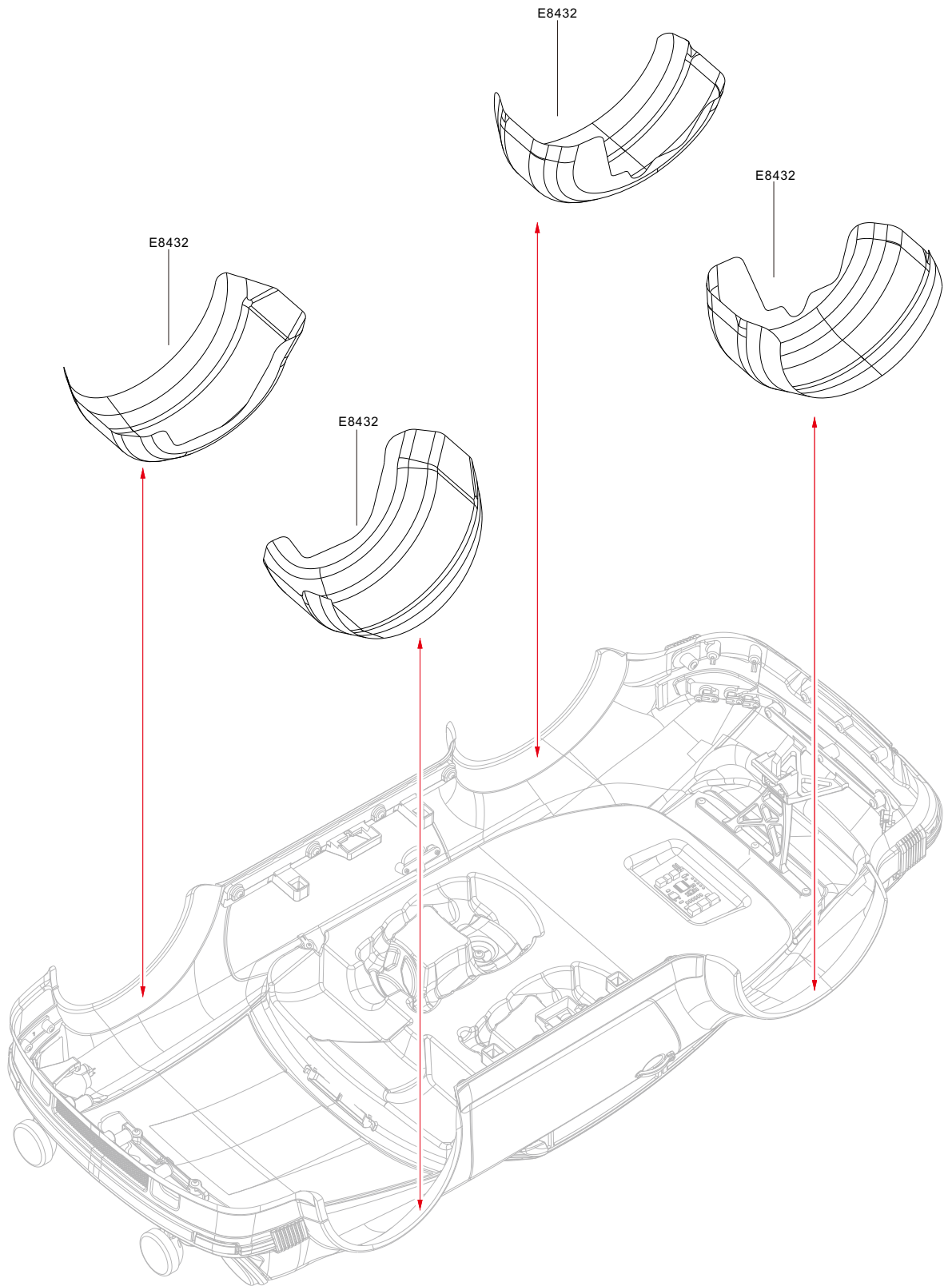

73

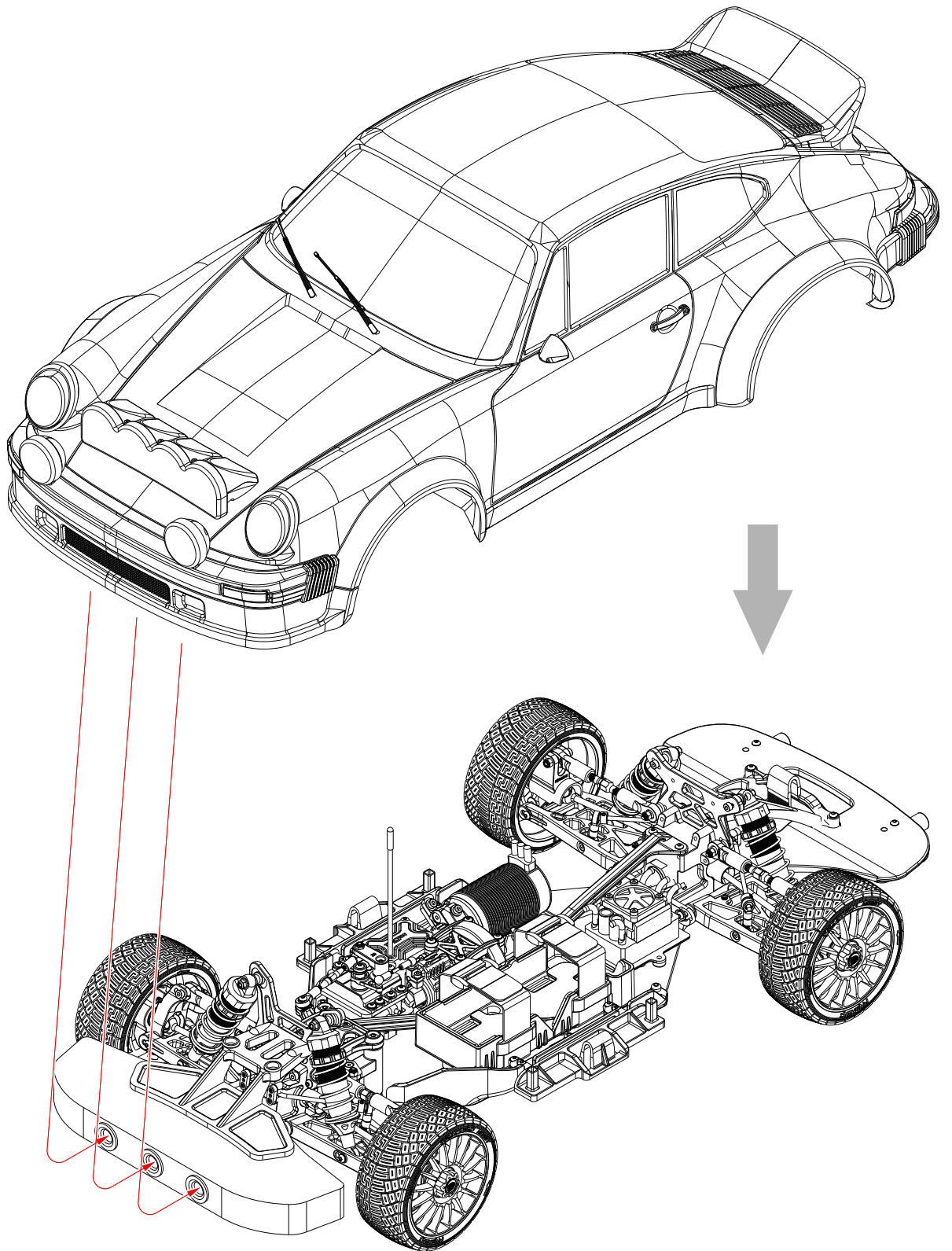

1/6 SCALE PORSCHE

PRIMAL RC

TRACTION
HOBBY



© 2025 Porsche AG. Porsche, Porsche Crest, and Porsche Logotype are trademark(s) of Porsche AG used under license

Gulf trademarks under license from GULF OIL LLC

